



Regulators

PR and BR Series

Contents

General-Purpose Pressure Regulators (PR1 Series)

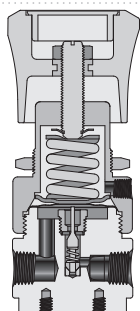

- ❖ Maximum rated Inlet pressure 3500 psig (241 bar)
- ❖ Flow capacity: Cv=0.06
- ❖ Metal-to-metal diaphragm seal

9-12

High-Flow Pressure Regulators (PR2 Series)

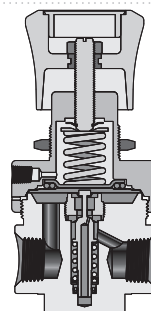

- ❖ Maximum rated Inlet pressure 3000 psig (206 bar)
- ❖ Flow capacity: Cv=1.0
- ❖ Metal-to-metal diaphragm seal

9-15

Piston Sensing Pressure Regulators (PR3 Series)

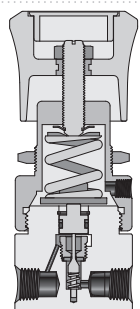

- ❖ Maximum rated Inlet pressure 6000 psig (413 bar)
- ❖ Flow capacity: Cv=0.06
- ❖ Piston sensed design

9-18

High-Pressure Pressure Regulators (PR4 Series)

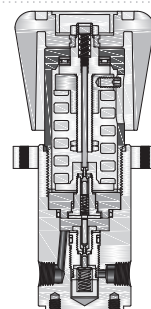

- ❖ Maximum rated inlet pressure 10000 psig (689 bar)
- ❖ Flow capacity: Cv=0.06
- ❖ The flow area of stem and body is large to ensure high flow

9-21

Compact Pressure Regulators (PR5 Series)

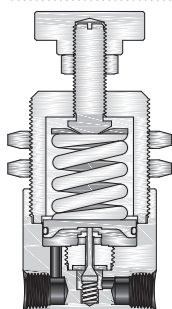

- ❖ Maximum rated Inlet pressure 3600psig (248bar)
- ❖ Flow capacity: Cv =0.06
- ❖ Lightweight and compact design
- ❖ Low internal volume
- ❖ Robust piston sensed design to provide safety and reliability

9-24

Ultra High-Flow Pressure Regulators (PR6 Series)

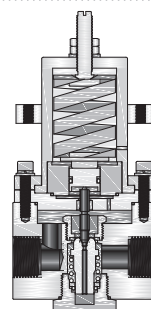

- ❖ Maximum rated Inlet pressure 6000psig (413bar)
- ❖ Flow capacity: Cv =3.5
- ❖ Robust piston sensed design to provide safety and reliability
- ❖ For non-corrosive gases (due to seal limit)

9-27

Contents

Two-Stage Pressure Regulators (DPR1 Series)

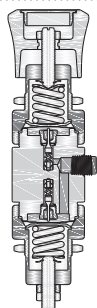

- ❖ Maximum rated Inlet pressure 3500 psig (241.4 bar)
- ❖ Flow capacity: Cv=0.05

9-30

General-Purpose Back-Pressure Regulators (BR1 Series)

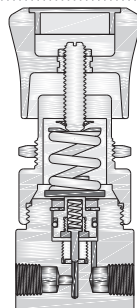

- ❖ Maximum rated Inlet pressure 800 psig (55.1 bar)
- ❖ Flow capacity: Cv=0.10
- ❖ Piston sensed design

9-32

High-Pressure Back-Pressure Regulators (BR2 Series)

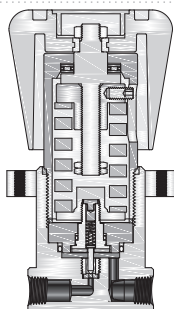

- ❖ Maximum Inlet pressure 10000 psig (689 bar)
- ❖ Flow capacity: Cv=0.10
- ❖ Bubble-tight shutoff at all reseating pressure

9-34

Low-Pressure Back-Pressure Regulators (BR3 Series)

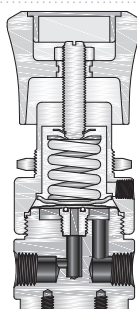

- ❖ Maximum inlet pressure: 250 psig (17.2bar)
- ❖ Flow capacity: Cv=0.30
- ❖ Optional materia 316 stainless steel, brass

9-37

General-Purpose Pressure Regulators

PR1 series

Applications

- ❖ Laboratory and point-of-use gas systems
- ❖ Sampling systems, zero, span and calibration analyzer gases
- ❖ Specialty and industrial gas cylinder regulator
- ❖ Chromatograph flame detector fuel supply

Features

- ❖ Compact
- ❖ Designed to minimize contamination and provide accurate regulation of any corrosive, noncorrosive, or toxic gas
- ❖ Metal-to-metal diaphragm to body seal ensures minimum inboard and outboard leakage
- ❖ Convoluted diaphragm delivers excellent accuracy and long service life
- ❖ Panel mounting is available



Operating Parameters

- ❖ Maximum Inlet Pressure: 3500 psig (241 bar)
- ❖ Outlet Pressure Ranges
0-25 psig (0-1.7 bar), 0-50 psig (0-3.4 bar), 0-100 psig (0-6.9 bar), 0-250 psig (0-17.2 bar), 0-500 psig (0-34.5 bar)
- ❖ Design Proof Pressure: 150% maximum rated
- ❖ Leakage
Internal: bubble-tight
External: design to meet $\leq 2 \times 10^{-8}$ atm cc/sec He
- ❖ Operating Temperature
PCTFE: -40°F to 176°F (-40°C to 80°C)
PEEK: -40°F to 392°F (-40°C to 200°C)
PI: -40°F to 500°F (-40°C to 260°C)
- ❖ Flow Capacity: Cv = 0.06

Standard Materials of Construction

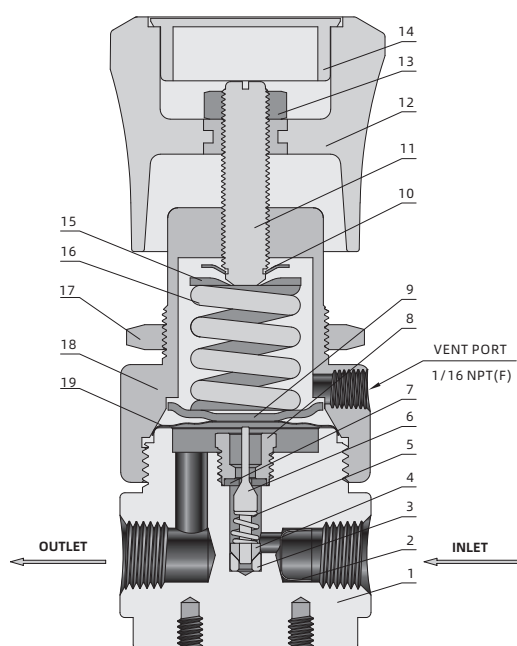

Component		Material Grade
1	Body	316 S.S. / ASTM A479
2	Filter	316L S.S.
3	Shock Absorber Support	316 S.S. / ASTM A479
4	Shock Absorber	PTFE/PEEK
5	Spool Spring	Alloy X-750
6	Spool	316 S.S. / ASTM A276
7	Seat	PCTFE / PEEK / PI
8	Seat Retainer	316 S.S. / ASTM A276
9	Stop Plate	316 S.S. / ASTM A276
10	Retaining Ring	65Mn
11	Stem	C36000
12	Handle	Nylon PA66
13	Stem Nut	304 S.S.
14	Cover	Nylon PA66
15	Spring Button	304 S.S.
16	Range Spring	Spring Steel
17	Mounting Nut	630 S.S.
18	Bonnet	316 S.S. / ASTM A479
19	Diaphragm	316 S.S.

Dimensions

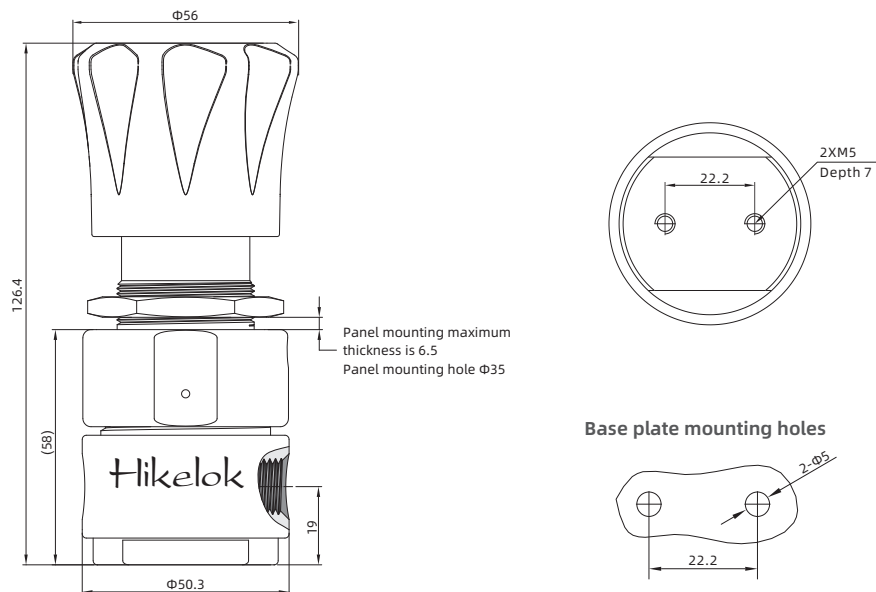

Flow Chart

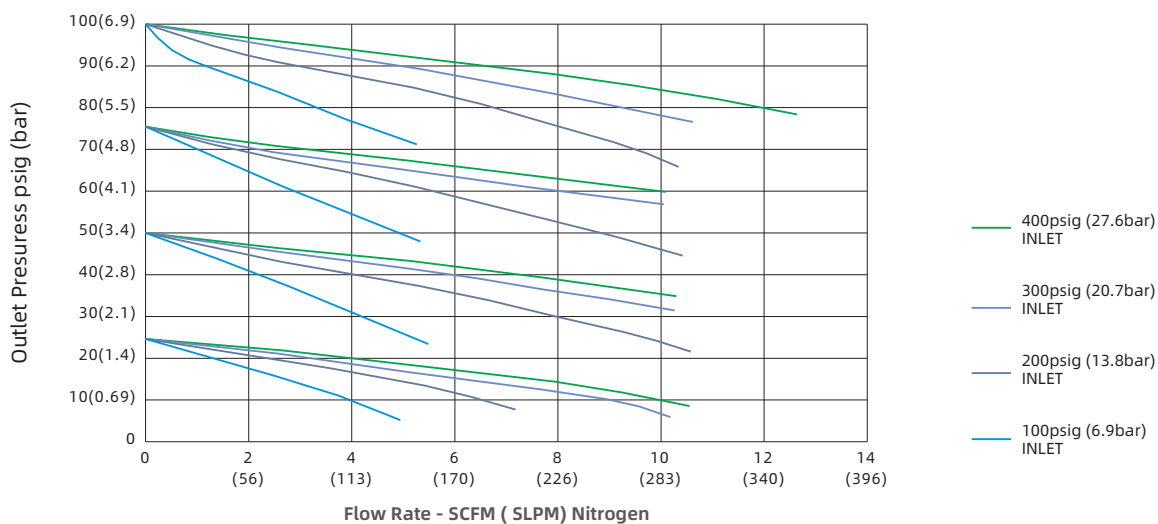
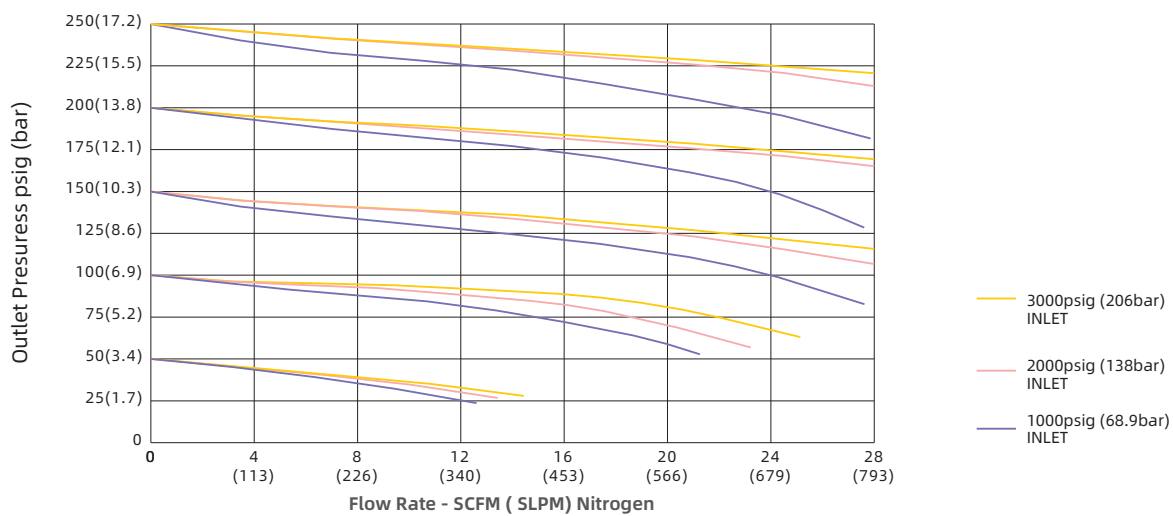

Path Options (LP=Low Pressure; HP=High Pressure)

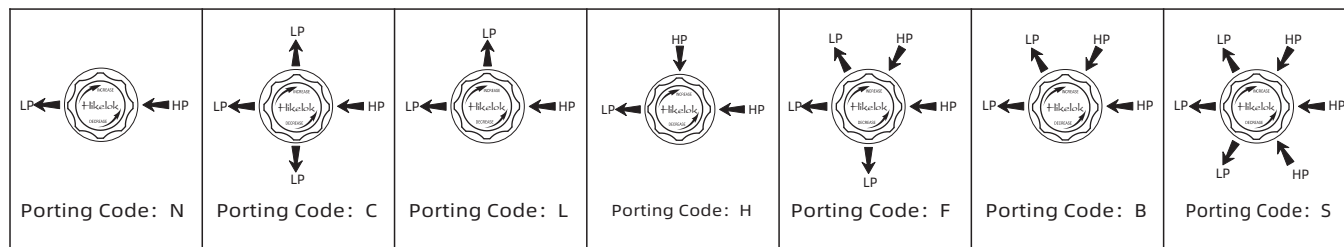

How to Order

PR1 — **FNPT4** — **IB** — **3500G** — **316L**

Series	Inlet Type Outlet Type	Inlet Size Outlet Size	Seat Material	Path Options	Inlet Pressure	Outlet Pressure	Gauges	Body Material
PR1	FNPT Female NPT FBT Female BSPT	4 1/4 in.	P PCTFE P PEEK I PI	N No Gauge Ports	3 3500 psig	500 0-500 psig	No G Yes	316 316 S.S. 316L 316L S.S. A400 Alloy 400 A276 Alloy C276
				L One Gauge Ports		250 0-250 psig		
				H One Gauge Ports		100 0-100 psig		
				C One Gauge Ports		50 0-50 psig		
				B Two Gauge Ports		25 0-25 psig		
				F Two Gauge Ports				
S Two Gauge Ports								

High-Flow Pressure Regulators

PR2 series

Applications

- ❖ Laboratory and Point-of-Use Gas Systems in medical, pharmaceutical, food and beverage, and other high purity applications
- ❖ Process analyzer gases, metal fabrication and specialty and industrial gas cylinders

Features

- ❖ Metal-to-metal diaphragm provides sensitivity for pressure control
- ❖ Balanced poppet design to reduce supply pressure effect
- ❖ Panel mounting is available



Operating Parameters

- ❖ Maximum Inlet Pressure: 3000 psig (206 bar)
- ❖ Outlet Pressure Ranges
0-25 psig (0-1.7 bar), 0-50 psig (0-3.4 bar), 0-100 psig (0-6.8 bar), 0-150 psig (0-10.3 bar), 0-200 psig (0-13.8 bar)
- ❖ Design Proof Pressure: 150% maximum rated
- ❖ Leakage
Internal: bubble-tight
External: design to meet $\leq 2 \times 10^{-8}$ mbar l/sec He
- ❖ Operating Temperature
PCTFE seat: -40°F to 176°F (-40°C to 80°C)
PEEK: -40°F to 392°F (-40°C to 200°C)
PI seat: -40 °F to 500 °F (-40 °C to 260 °C)
- ❖ Flow Capacity: $C_v = 1.0$

Standard Materials of Construction

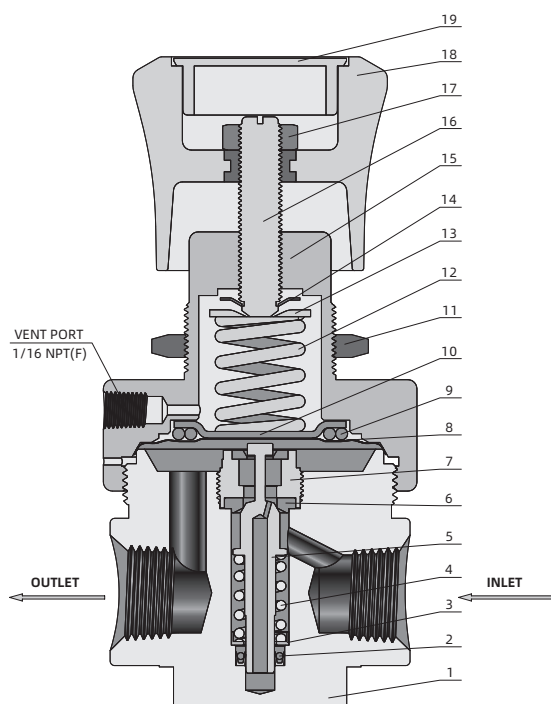

Component		Material Grade
1	Body	316 S.S. / ASTM A479
2	O-Ring	FKM/FFKM
3	Spring Base	316 S.S. / ASTM A276
4	Spool Spring	Alloy X-750
5	Spool	316 S.S. / ASTM A276
6	Seat	PCTFE / PEEK / PI
7	Seat Retainer	316 S.S. / ASTM A276
8	Diaphragm	316 S.S.
9	Support Ring	PTFE
10	Stop Plate	316 S.S./ASTM A276
11	Mounting Nut	630 S.S.
12	Range Spring	Spring Steel
13	Spring Button	Galvanized Steel
14	Retaining Ring	65Mn
15	Bonnet	316 S.S. / ASTM A479
16	Stem	C36000
17	Stem Nut	304 S.S.
18	Handle	Nylon PA66
19	Cover	Nylon PA66

Dimensions

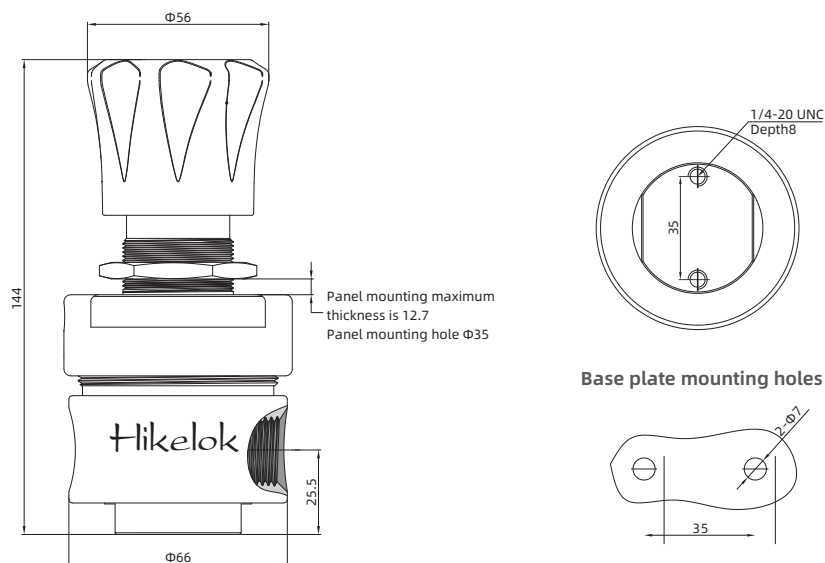

Flow Chart

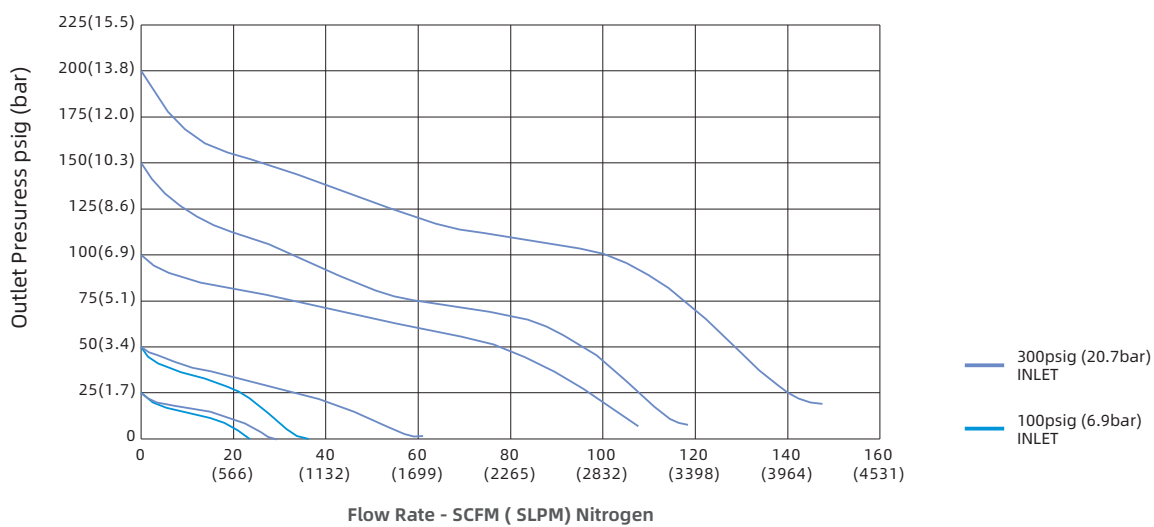
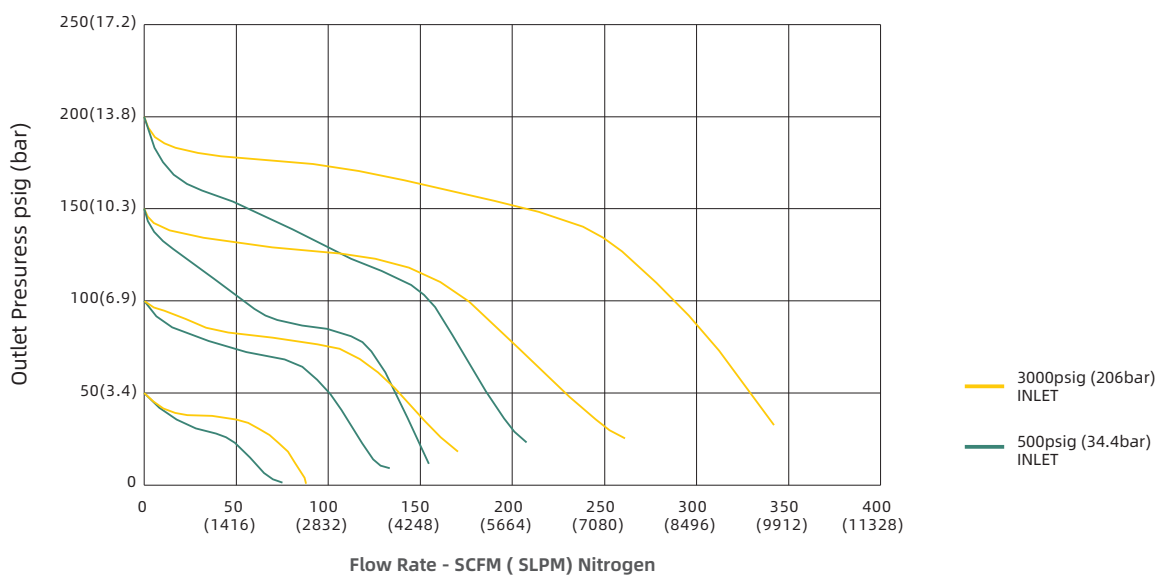

Path Options (LP=Low Pressure; HP=High Pressure)

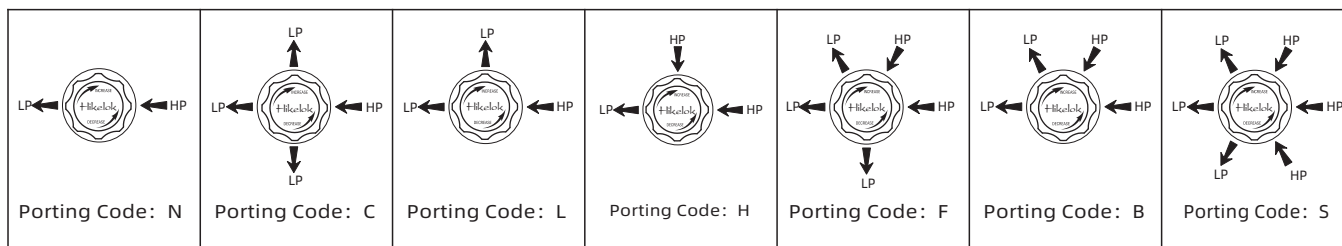

How to Order

PR2 — **FNPT8** — **IB** — **3200G** — **316L**

Series	Inlet Type Outlet Type	Inlet Size Outlet Size	Seat Material	Porting	Inlet Pressure	Outlet Pressure	Gauges	Body Material
PR2	FNPT Female NPT	6 3/8 in.	PCTFE	N No Gauge Ports	3 3000 psig	200 0-200 psig	No gauges	316 316 S.S.
	FBT Female BSPT	8 1/2 in.	P PEEK	L One Gauge Ports		150 0-150 psig	G with gauges	316L 316L S.S.
				H One Gauge Ports		100 0-100 psig		A400 Alloy 400
				C One Gauge Ports		50 0-50 psig		A276 Alloy C276
				B Two Gauge Ports		25 0-25 psig		
				F Two Gauge Ports				
				S Two Gauge Ports				
I PI								

Piston Sensing Pressure Regulators

PR3 series

Applications

- ❖ Laboratory and point-of-use gas systems
- ❖ Sampling systems, zero, span and calibration analyzer gases
- ❖ Specialty and industrial gas cylinder regulator
- ❖ Chromatograph flame detector fuel supply

Features

- ❖ Compact
- ❖ Piston sensed design
- ❖ Venting model is available
- ❖ Panel mounting is available



Operating Parameters

- ❖ Maximum Inlet Pressure: 6000 psig (413 bar) @ 70°F (21°C)
- ❖ Outlet Pressure Ranges
0-250 psig (0-17.2 bar), 0-500 psig (0-34.4 bar), 0-1500 psig (0-103.4 bar), 0-2500 psig (0-172 bar)
- ❖ Design Proof Pressure: 150% maximum rated
- ❖ Leakage
Internal: bubble-tight
- ❖ Operating Temperature
PCTFE: -40°F to 165°F (-40°C to 74°C)
PEEK: -40°F to 392°F (-40°C to 200°C)
PI: -40°F to 500°F (-40°C to 260°C)
- ❖ Flow Capacity: Cv = 0.06

Standard Materials of Construction

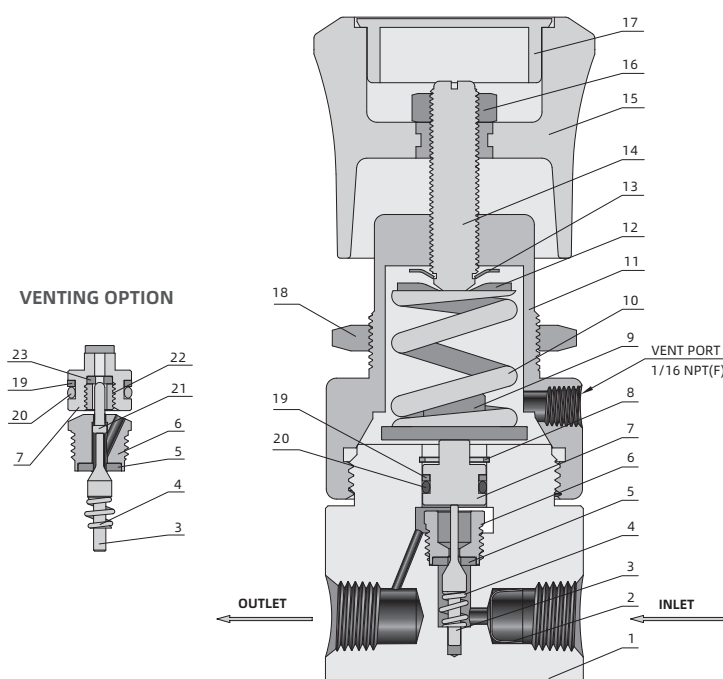

Component		Material Grade
1	Body	316 S.S. / ASTM A479
2	Filter	316L S.S.
3	Spool	316 S.S. / ASTM A276
4	Spool Spring	Alloy X-750
5	Seat	PCTFE / PEEK / PI
6	Seat Retainer	316 S.S. / ASTM A276
7	Piston	316 S.S. / ASTM A276
8	Spring Retaining Ring	304 S.S. / ASTM A313
9	Stop Plate	C36000
10	Range Spring	Spring Steel
11	Bonnet	316 S.S. / ASTM A479
12	Spring Button	Galvanized Steel
13	Retaining Ring	65Mn
14	Stem	C36000
15	Handle	Nylon PA66
16	Stem Nut	304 S.S.
17	Cover	Nylon PA66
18	Mounting Nut	630 S.S.
19	Seal Backup Ring	PTFE/PEEK
20	Piston seal	FKM / FFKM
21	Self-vent poppet	316 S.S. / ASTM A276
22	Self-vent seat retainer	316 S.S. / ASTM A276
23	Self-vent seat	PCTFE / PEEK / PI

Dimensions

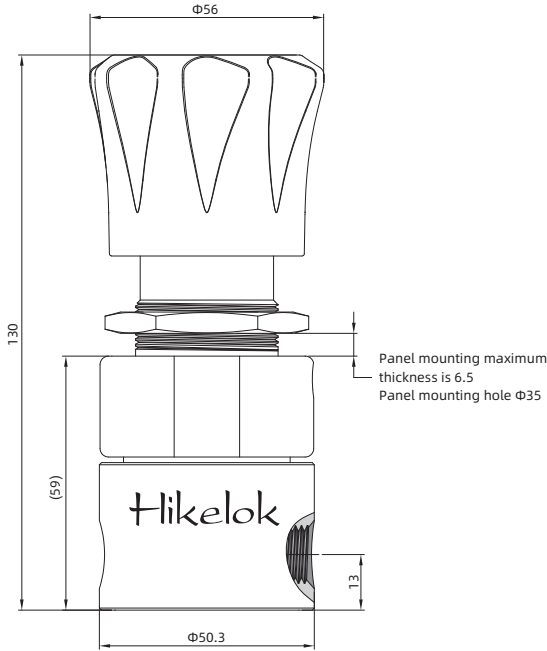

Flow Chart

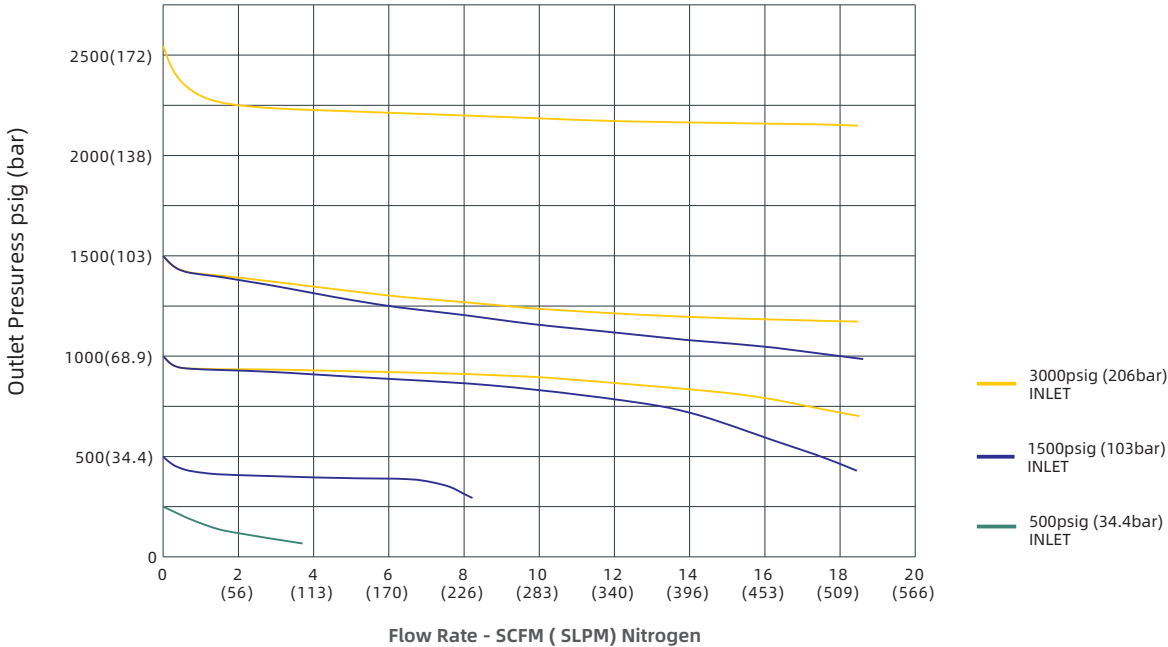

Path Options (LP=Low Pressure; HP=High Pressure)

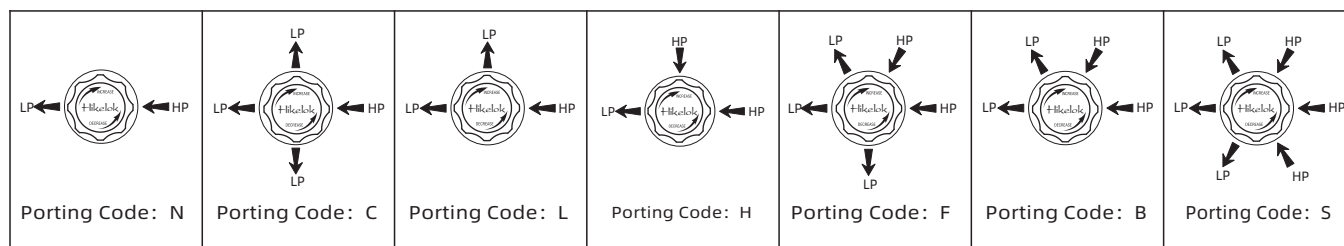

How to Order

PR3 — **FNPT4** — **IB** — **62500G** — **V** — **316L**

Series	Inlet Type Outlet Type	Inlet Size Outlet Size	Seat Material	Porting	Inlet Pressure	Outlet Pressure	Gauges	Venting Option	Body Material
PR3	FNPT Female NPT FBT Female BSPT	4 1/4 in.	PCTFE PEEK PI	N No Gauge Ports	6 6000 psig	2500 0-2500 psig	No gauges G with gauges	NO V Venting	316 316 S.S.
				L One Gauge Ports		1500 0-1500 psig			316L 316L S.S.
				H One Gauge Ports		500 0-500 psig			A400 Alloy 400
				C One Gauge Ports		250 0-250 psig			A276 Alloy C276
				B Two Gauge Ports					
				F Two Gauge Ports					
				S Two Gauge Ports					

High-Pressure Pressure Regulators

PR4 series

Features

- ❖ Lightweight and compact design
- ❖ For high pressure system
- ❖ Robust piston sensed design to provide safety and reliability
- ❖ For non-corrosive gases (due to seal limit)
- ❖ Panel mounting
- ❖ The operating torque is small and the adjustment is convenient

Technical Data

- ❖ Maximum inlet pressure: 10000 psig (689 bar) @ 70°F (21°C)
- ❖ Outlet pressure range
5-500 psig (0.3-34.4 bar), 5-800 psig (0.3-55.1 bar),
10-1500 psig (0.7-103 bar), 15-2500 psig (1.0-172 bar),
25-4000 psig (1.7-275 bar), 50-6000 psig (3.4-413 bar)
- ❖ Design Proof Pressure: 150% maximum rated
- ❖ Optional material: 316 S.S., 316L S.S., Alloy400, Alloy C276.
- ❖ Optional seat: PEEK(standard), PI(optional)
- ❖ Operating Temperature:
PEEK: -40°F to 212°F (-40°C to 100°C)
PI: -40°F to 250°F (-40°C to 121°C)
- ❖ Flow Capacity: Cv=0.06



Standard Materials of Construction

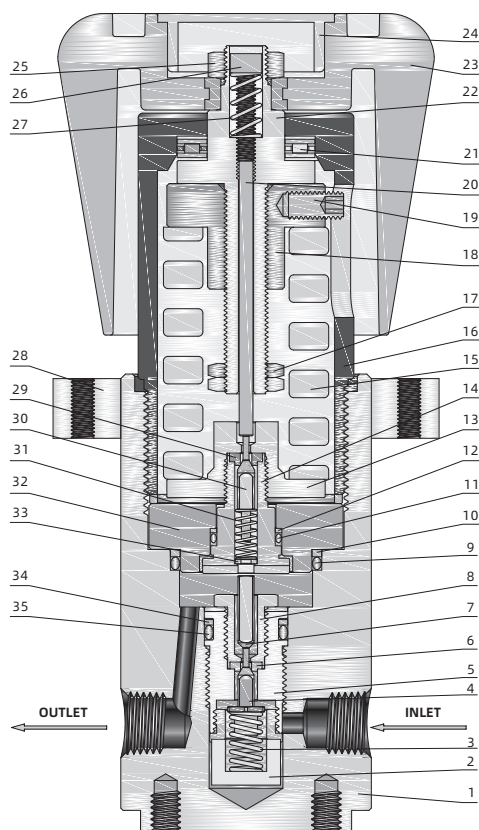

Component	Material Grade	
1	Body	316 S.S./ASTM A479
2	Filter	316 S.S.
3	Spring	X-750/AMS 5678
4	Spool	316 S.S./ASTM A276
5	Seat Base	316 S.S./ASTM A276
6	Seat	PEEK/PI
7	Ejector Rod	316 S.S./ASTM A276
8	Seat retainer	316 S.S./ASTM A276
9	O Ring	FKM/FFKM
10	O-ring Retaining Ring	PTFE/PEEK
11	O Ring	FKM/FFKM
12	O-ring Retaining Ring	PTFE/PEEK
13	Stop Plate	C36000/ASTM B16
14	Piston	316 S.S./ASTM A276
15	Spring	Galvanized Steel
16	Bonnet	316 S.S./ASTM A276
17	Nut	304 S.S.
18	Spring Button	C36000/ASTM B16
19	Screw	304 S.S.
20	Ejector Rod	316 S.S./ASTM A276
21	Bearing	Stainless Steel
22	Stem	316 S.S./ASTM A276
23	Handle	Nylon PA66
24	Handle Cover	Nylon PA66
25	Nut	304 S.S.
26	Screw	304 S.S.
27	Spring	316 S.S./ASTM A313
28	Mounting Seat	6061/ASTM B211
29	Seat	PCTFE/PEEK
30	Spool	316 S.S./ASTM A276
31	Spring	X-750/AMS 5678
32	Piston Base	316 S.S./ASTM A276
33	Spring Seat	316 S.S./ASTM A276
34	O-ring Retaining Ring	PTFE/PEEK
35	O Ring	FKM/FFKM

Dimensions

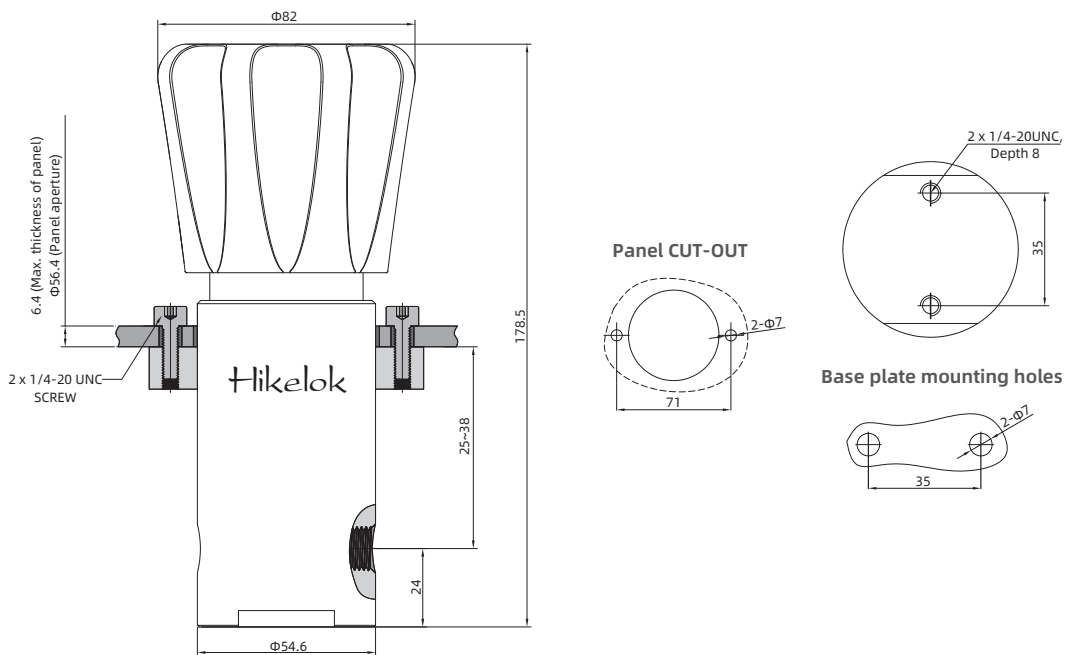

Flow Chart

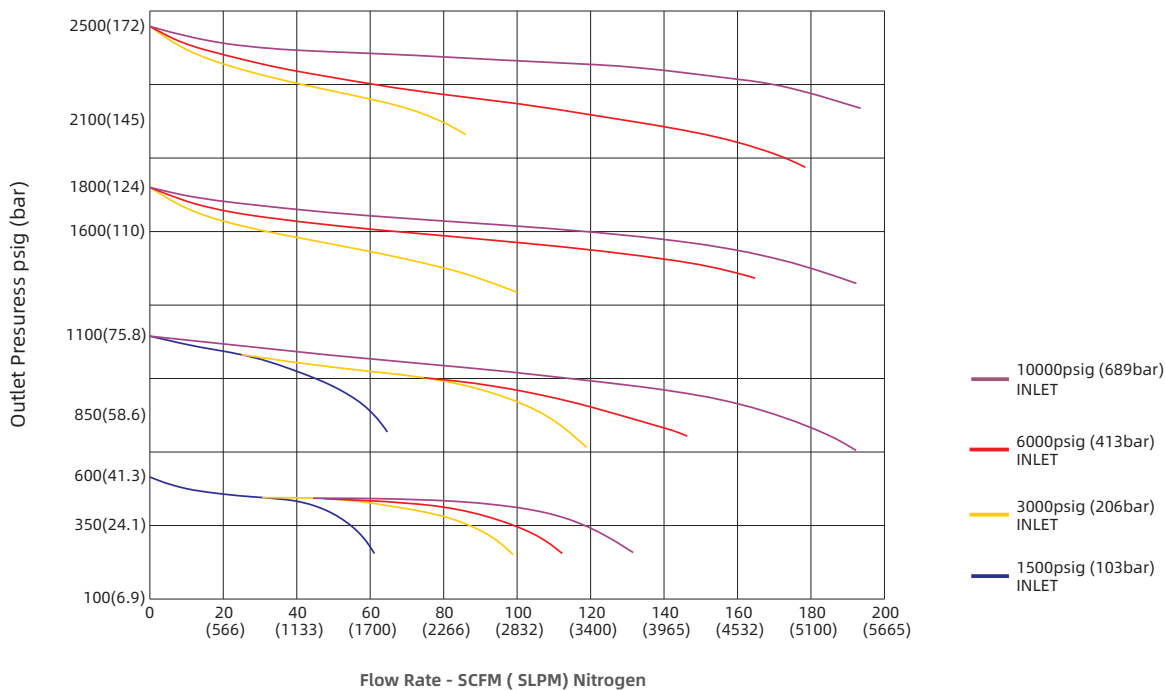

Path Options (LP=Low Pressure; HP=High Pressure)

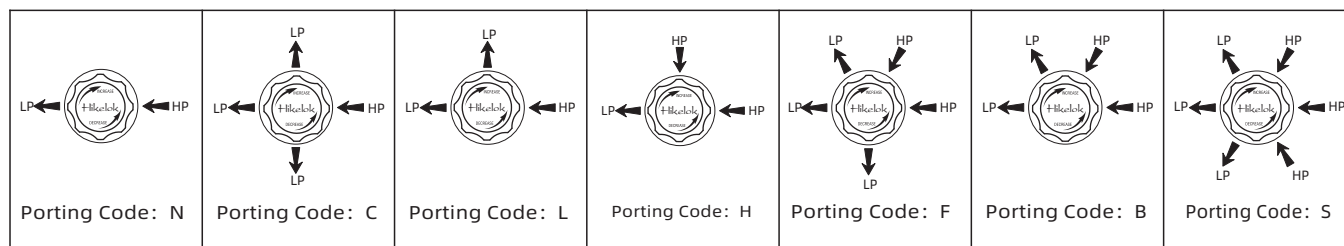

How to Order

PR4 — **FNPT4** — **IB** — **106000G** — **316L**

Series	Inlet Type Outlet Type	Inlet Size Outlet Size	Seat Material	Porting	Inlet Pressure	Outlet Pressure	Gauges	Body Material
PR4	FNPT Female NPT FBT Female BSPT	4 1/4 in.	PEEK I PI	N No Gauge Ports	10 10000 psig	6000 50-6000 psig	No	316 316 S.S.
				L One Gauge Ports		4000 25-4000 psig	G Yes	316L 316L S.S.
				H One Gauge Ports		2500 15-2500 psig		A400 Alloy 400
				C One Gauge Ports		1500 10-1500 psig		A276 Alloy C276
				B Two Gauge Ports		800 5-800 psig		
				F Two Gauge Ports		500 5-500 psig		
				S Two Gauge Ports				

Compact Pressure Regulators

PR5 series

Features

- ❖ Lightweight and compact design
- ❖ Low internal volume
- ❖ Robust piston sensed design to provide safety and reliability
- ❖ For non-corrosive gases (due to seal limit)
- ❖ Panel mounting
- ❖ The operating torque is small and the adjustment is convenient

Technical Data

- ❖ Maximum inlet pressure: 3600 psig (248 bar)
0-10 psig (0-0.68 bar), 0-25 psig (0-1.7 bar), 0-50 psig (0-3.4 bar), 0-100 psig (0-6.8 bar),
0-150 psig (0-10.3 bar), 0-250 psig (0-17.2 bar), 0-500 psig (0-34.4 bar), 0-1000 psig (0-68.9 bar),
0-1500 psig (0-103 bar).
- ❖ Design Proof Pressure: 150% maximum rated
- ❖ Leakage
Internal: bubble-tight
- ❖ Operating Temperature
PCTFE: -40°F to 140°F (-40°C to 60°C)
PEEK: -40°F to 392°F (-40°C to 200°C)
- ❖ Flow Capacity: Cv = 0.06



Standard Materials of Construction

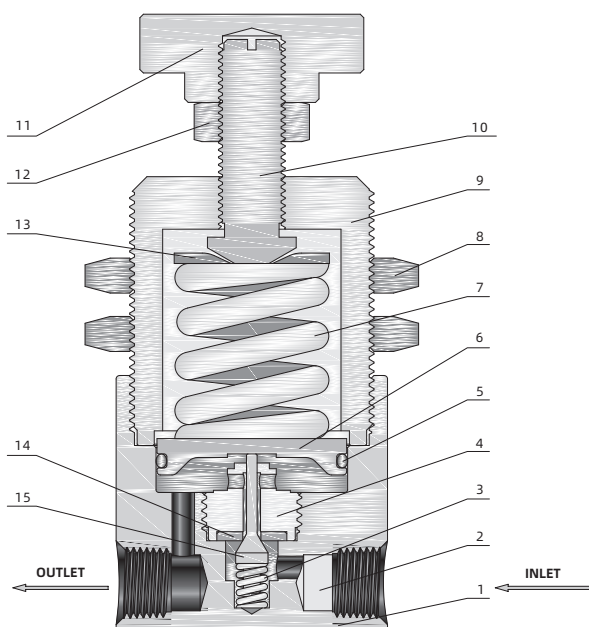

Component	Material Grade
1 Body	316 S.S. / ASTM A479
2 Filter	316 S.S. / ASTM A276
3 Spring	Spring Steel
4 Spring Seat	316 S.S. / ASTM A240
5 O-Ring	FKM/FFKM
6 Piston	316 S.S. / ASTM A276
7 Spring	Spring Steel
8 Mounting Nut	S17400 / ASTM B783
9 Bonnet	316 S.S. / ASTM A276
10 Stem	C63000 / ASTM B150
11 Handle	Nylon PA66
12 Nut	304 S.S.
13 Spring Button	Galvanized Steel
14 Seat	PCTFE/PEEK
15 Spool	316 S.S. / ASTM A276

Dimensions

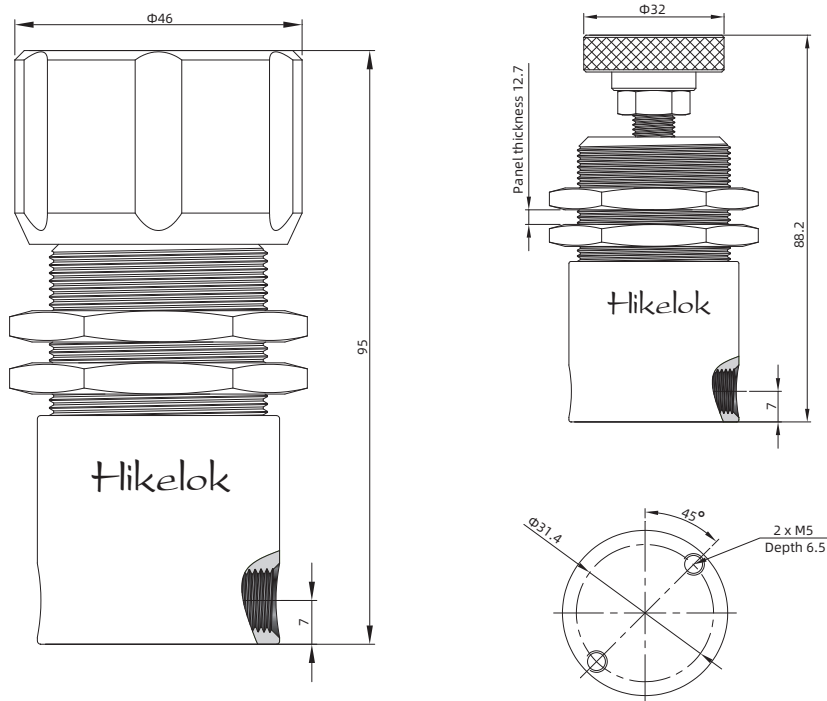

Flow Chart

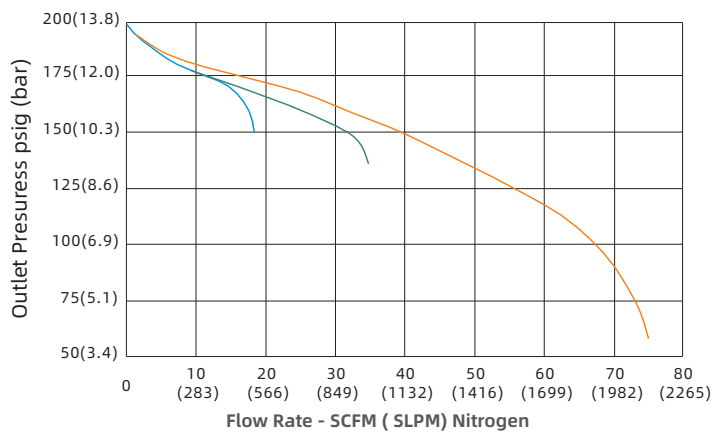
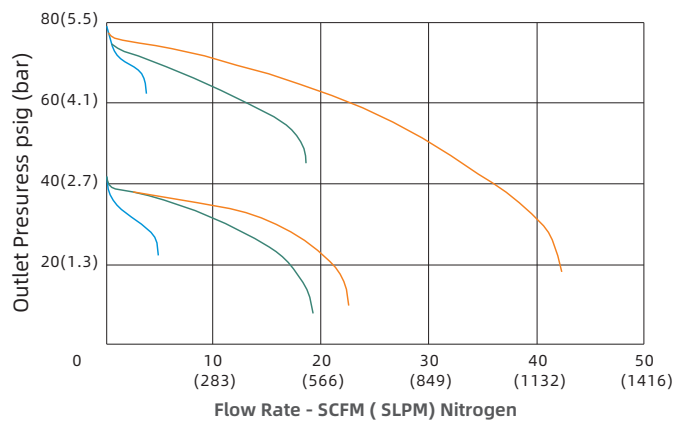
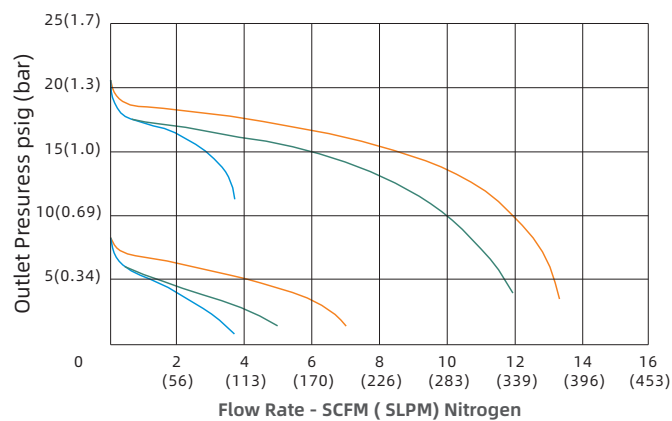

- 2200psig (151bar) INLET
- 500psig (34.4bar) INLET
- 100psig (6.9bar) INLET

Path Options (LP=Low Pressure; HP=High Pressure)

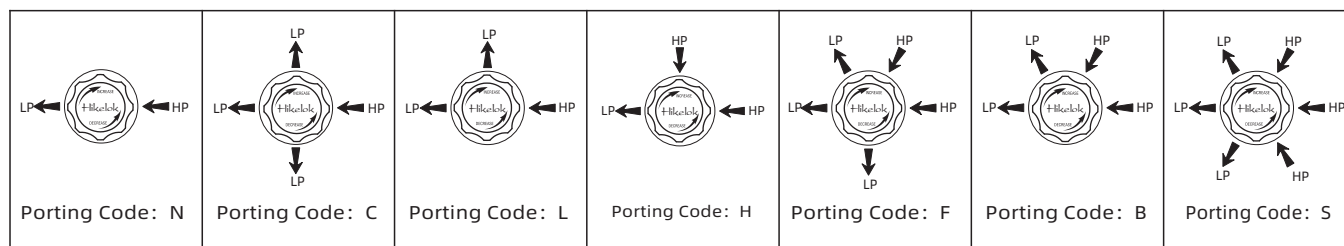

How to Order

PR5 — FNPT2 — H — 325G — K — 316L

Series	Inlet Type Outlet Type	Inlet Size Outlet Size	Seat Material	Porting	Inlet Pressure	Outlet Pressure	Gauges	Handle Type	Body Material	
PR5	FNPT Female NPT	2 1/8 in.	PCTFE	N No Gauge Ports	3 3600 psig	1500 0-1500 psig	No	Thumbwheel	316 316 S.S. 316L 316L S.S. A400 Alloy 400 A276 Alloy C276	
	FBT Female BSPT		P PEEK	L One Gauge Ports		1000 0-1000 psig	G Yes			K Knob
				H One Gauge Ports		500 0-500 psig				
				C One Gauge Ports		250 0-250 psig				
				B Two Gauge Ports		100 0-100 psig				
				F Two Gauge Ports		50 0-50 psig				
				S Two Gauge Ports		25 0-25 psig				
				10 0-10 psig						

Ultra High-Flow Pressure Regulators

PR6 series

Features

- ❖ Robust piston sensed design to provide safety and reliability
- ❖ For non-corrosive gases (due to seal limit)
- ❖ Panel mounting
- ❖ The operating torque is small and the adjustment is convenient

Technical Data

- ❖ Maximum inlet pressure: 6000 psig (413 bar) @ 70°F (21°C) or 3000 psig (206 bar) @ 70°F (21°C)
- ❖ Outlet pressure range:
0-150 psig (0-10.3 bar), 0-360 psig (0-24.8 bar), 0-700 psig (0-48.2 bar), 0-1000 psig (0-68.9 bar),
0-2200 psig (0-151 bar), 0-3600 psig (0-248 bar), 0-5000 psig (0-344 bar)
- ❖ Design Proof Pressure: 150% maximum rated
- ❖ Optional material: 316 S.S., 316L S.S..
- ❖ Optional seat: PCTFE(standard); PEEK, PI(optional)
- ❖ Operating Temperature:
PCTFE: -40°F(-40°C) to 176°F(80°C)
PEEK: -40°F(-40°C) to 392°F(200°C)
PI: -40°F(-40°C) to 500°F(260°C)
- ❖ Flow Capacity: Cv=3.5



Standard Materials of Construction

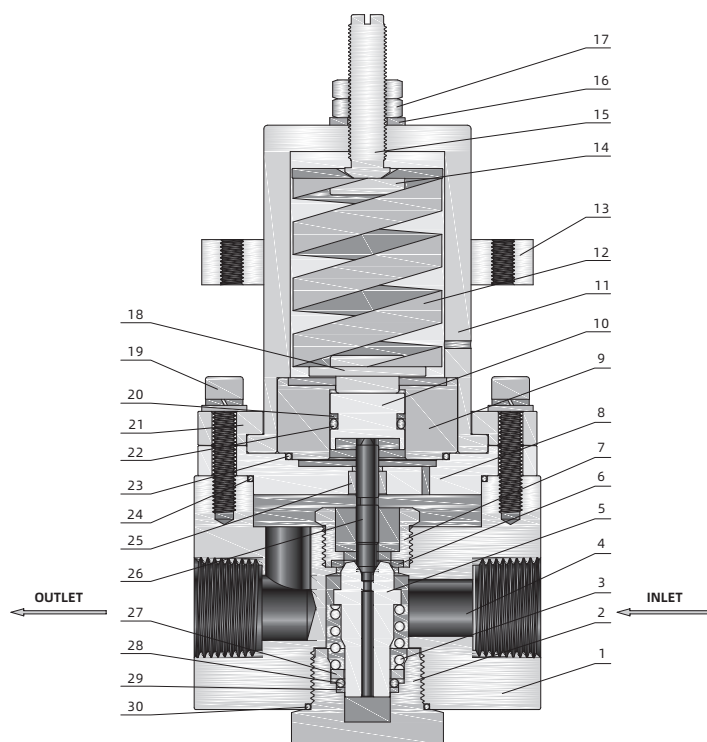

Component	Material Grade	
1	Body	316 S.S. / ASTM A479
2	Base Bolt	316 S.S. / ASTM A479
3	Spring	X-750 / AMS 5678
4	Filter	316 S.S.
5	Spool	316 S.S. / ASTM A276
6	Seat	PCTFE/PEEK/PI
7	Seat Retainer	316 S.S. / ASTM A276
8	Fixed Ring	316 S.S. / ASTM A276
9	Piston Base	316 S.S. / ASTM A276
10	Piston	316 S.S. / ASTM A276
11	Bonnet	316 S.S. / ASTM A276
12	Spring	Galvanized Steel
13	Mounting Seat	6061 / ASTM B211
14	Spring button	Galvanized Steel
15	Stem	316 S.S. / ASTM A276
16	Flat Washer	304 S.S.
17	Nut	304 S.S.
18	Stop plate	Galvanized Steel
19	Screw	304 S.S.
20	O-ring Retaining Ring	PTFE
21	Gland	316 S.S. / ASTM A276
22	O-Ring	FKM/FFKM
23	O-Ring	FKM/FFKM
24	O-Ring	FKM/FFKM
25	Bearing	PTFE
26	Spool	316 S.S. / ASTM A276
27	Spring Seat	316 S.S. / ASTM A276
28	O-Ring	FKM/FFKM
29	O-ring Retaining Ring	PTFE/PEEK
30	O-Ring	FKM/FFKM

Dimensions

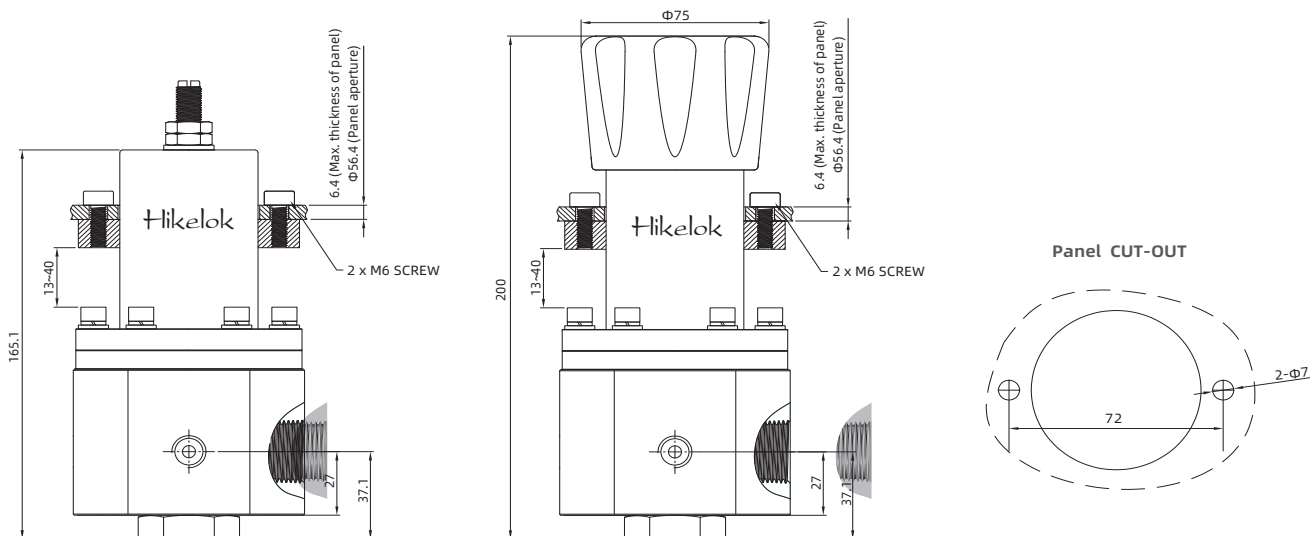

Flow Chart

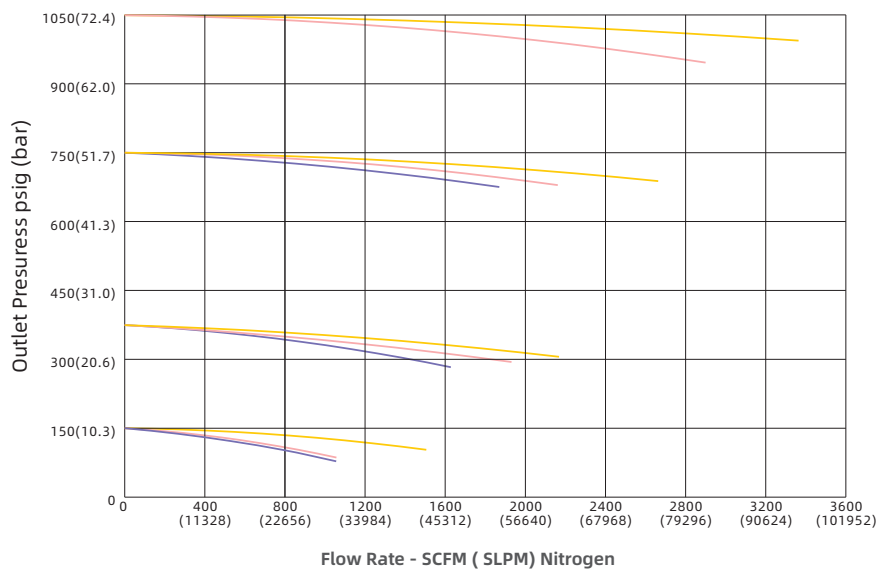
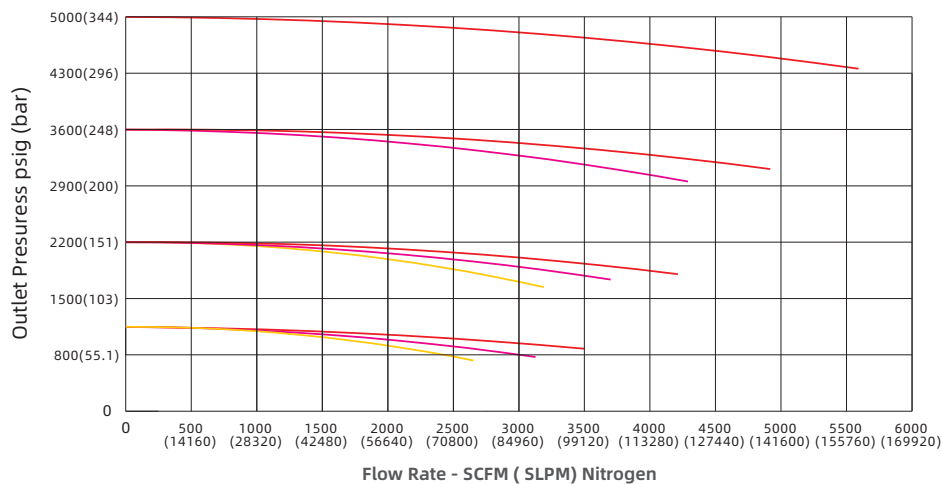

Path Options (LP=Low Pressure; HP=High Pressure)

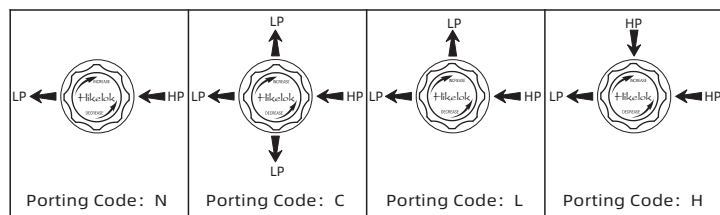

How to Order

PR6 — FNPT12 — IL — 3150G — BT — 316L

Series	Inlet Type Outlet Type	Inlet Size Outlet Size	Seat Material	Porting	Inlet Pressure	Outlet Pressure	Gauges	Handle Type	Body Material
PR6	FNPT Female NPT	8 1/2 in.	PCTFE	N No Gauge Ports	6 6000 psig	5000 0-5000 psig	No	Thumbwheel	316 316 S.S.
	FBT Female BSPT	12 3/4 in. 16 1 in.	P PEEK I PI	L One Gauge Ports	3 3000 psig	3600 0-3600 psig	G Yes	BT Knob Screw	316L 316L S.S.
				H One Gauge Ports		2200 0-2200 psig			A400 Alloy 400
				C One Gauge Ports		1000 0-1000 psig			A276 Alloy C276
					700 0-700 psig				
						360 0-360 psig			
						150 0-150 psig			

Two-Stage Pressure Regulators

DPR1 Series

Applications

- ❖ Laboratory and point-of-use gas systems
- ❖ Sampling systems, zero, span and calibration analyzer gases
- ❖ Specialty and industrial gas cylinder regulator
- ❖ Chromatograph flame detector fuel supply

Features

- ❖ Application: Specialty: flammable, industrial gases and liquid
- ❖ Two-stage decomposition structure provides more stable outlet pressure
- ❖ Watery diaphragm provides higher precision and sensitivity
- ❖ Low operating torque for easy adjustment

Operating Parameters

- ❖ Maximum inlet pressure: 3500psig (241.4bar)
- ❖ Outlet pressure range:
0-25 psig (0-1.7 bar), 0-50psig (0-3.5 bar), 0-100 psig (0-6.9 bar),
0-150 psig (0-10.3 bar), 0-250psig (0-17.2 bar)
- ❖ Leakage:
Internal: bubble-tight
External: design to meet $\leq 2 \times 10^{-8}$ atm cc/sec He
- ❖ Design proof pressure: 150% × Maximum rated pressure
- ❖ Optional seat: PCTFE(standard), PTFE, PEEK, PI(optional)
PCTFE: -40°F to 176°F (-40°C to 80°C)
PEEK: -40°F to 392°F (-40°C to 200°C)
PI: -40°F to 500°F (-40°C to 260°C)
- ❖ Flow capacity: Cv=0.05



Standard Materials of Construction

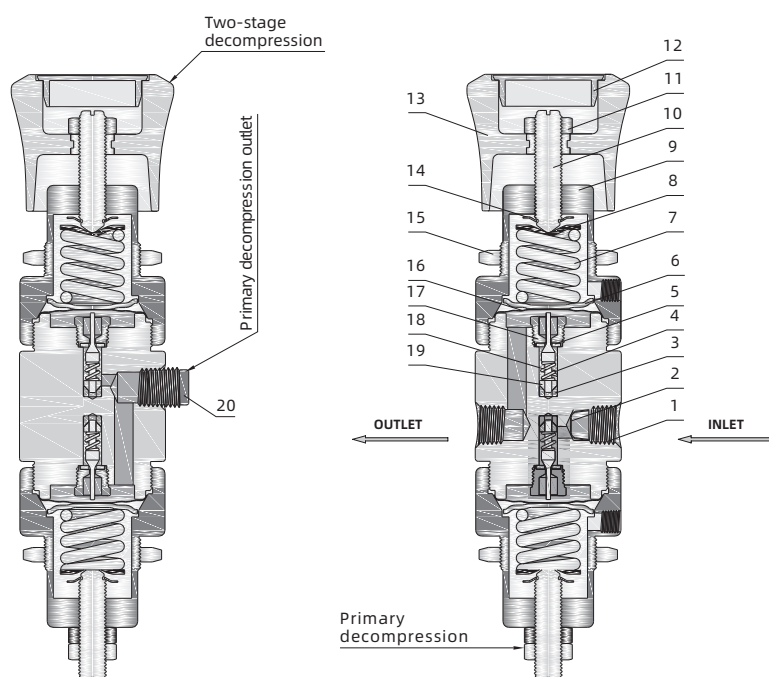

Component		Material Grade
1	Body	316 S.S./ASTM A479
2	Strainer	316 S.S./ASTM A313
3	Guide Nut	316 S.S./ASTM A276
4	Spring	X-750/AMS 5678
5	Seat	PCTFE/PEEK/PI
6	Spring Seat	316 S.S./ASTM 240
7	Spring	Spring Steel
8	Spring Button	304 S.S.
9	Bonnet	316 S.S./ASTM A276
10	Stem	C36000
11	Nut	304 S.S.
12	Handle Cover	Nylon PA66
13	Handle	Nylon PA66
14	Bead Flange	Galvanized Steel
15	Mounting Nut	S17400/ASTM B783
16	Diaphragm	316 S.S./ASTM A240
17	Seat Retainer	316 S.S./ASTM A276
18	Main Valve Stem	316 S.S./ASTM A276
19	Damping Ring	PTFE/PEEK
20	Plug	316 S.S./ASTM A276

Dimensions

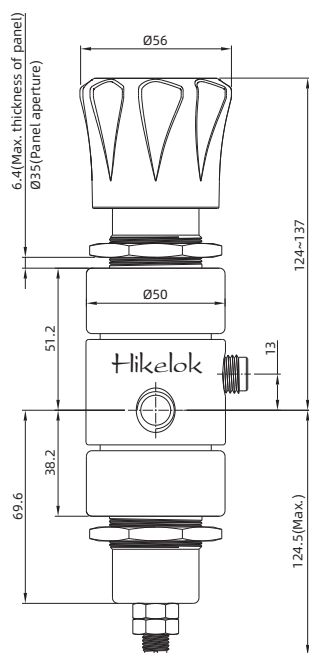

Flow Chart

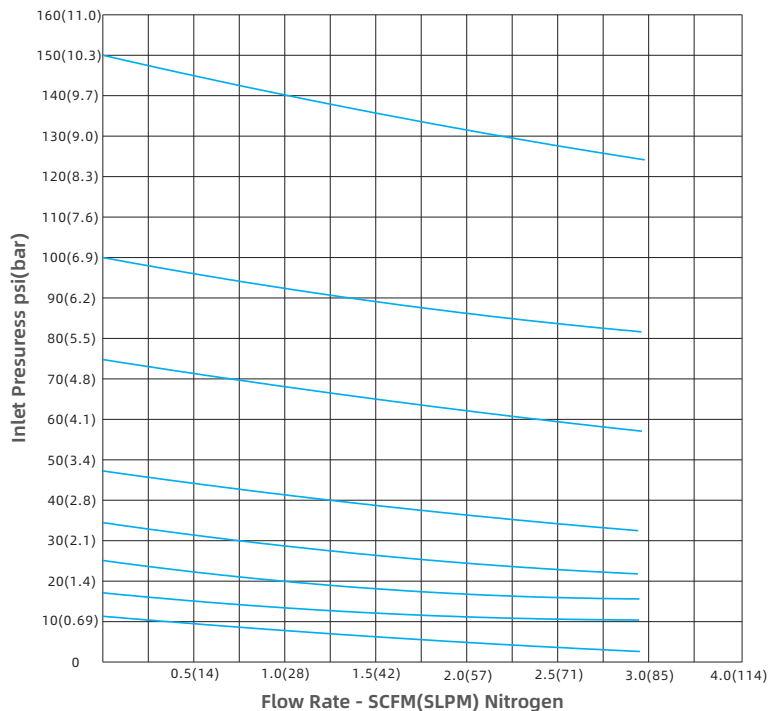

Path Options (LP=Low Pressure; HP=High Pressure)

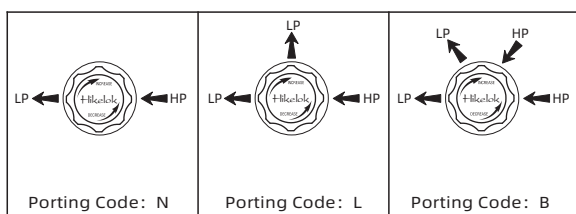

How to Order

Series	Inlet Type Outlet Type	Inlet Size Outlet Size	Seat Material	Porting	Inlet Pressure	Outlet Pressure	Gauges	Material
DPR1	FNPT Female NPT	4 1/4 in.	PCTFE	N No Gauge Ports	3 3500psig	250 0-250psig	No	316 316 S.S.
	FBT Female BSPT		T PTFE	L One Gauge Ports		150 0-150psig	G Yes	
			P PEEK	B Two Gauge Ports		100 0-100psig		
			I PI			50 0-50psig		
						25 0-25psig		

❖ Consolidation of inlet and outlet at the same time.

General-Purpose Back-Pressure Regulators

BR1 series

Applications

- ❖ Industrial equipment for hydraulic or pneumatic service

Features

- ❖ Economical, compact design
- ❖ Piston sensed design is safe and reliable
- ❖ Optional gauge ports and panel mounting
- ❖ Low handknob torque for easy operation
- ❖ Bubble-tight shutoff at all reseating pressure



Operating Parameters

- ❖ Maximum Inlet Pressure: 800 psig (55.1 bar)
- ❖ Controlled Pressure Ranges
40-150 psig (2.75-10.3 bar), 40-300 psig (2.75-20.6 bar),
100-700psig (6.89-48.2 bar), 100-800 psig (6.89-55.1 bar)
- ❖ Design Proof Pressure: 150% maximum rated
- ❖ Leakage
Bubble-tight
- ❖ Operating Temperature
PCTFE: 40°F to 140°F (-40°C to 60°C)
PEEK: -40°F to 392°F (-40°C to 200°C)
PI: -40°F to 500°F(-40°C to 260°C)
- ❖ Flow Capacity: Cv=0.10

Standard Materials of Construction

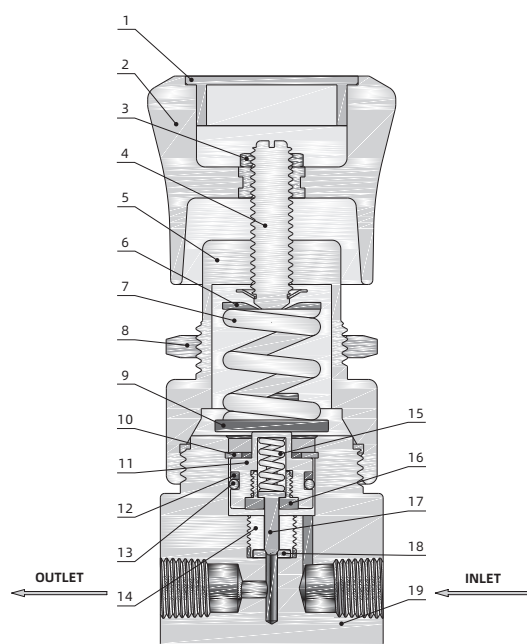

Component		Material Grade / ASTM Specification
		316 S.S.
1	Cover	ABS
2	Knob handle	ABS
3	Stem nut	316 S.S.
4	Stem	316 S.S.
5	Bonnet	316 S.S. / A479
6	Spring button	316 S.S. / A276
7	Range spring	316 S.S.
8	Mounting nut	316 S.S. / A276
9	Spring seat	Brass
10	Stretch block	304 S.S.
11	Piston	316 S.S. / A276
12	Retainer-ring	PTFE/PEEK
13	O-ring	FKM/FFKM
14	Seat retainer	316 S.S. / A276
15	Poppte spring	302 S.S.
16	Piston guide	316 S.S. / A276
17	Poppet	316 S.S. / A276
18	Seat	PCTFE/PEEK/PI
19	Body	316 S.S. / A479

Dimensions

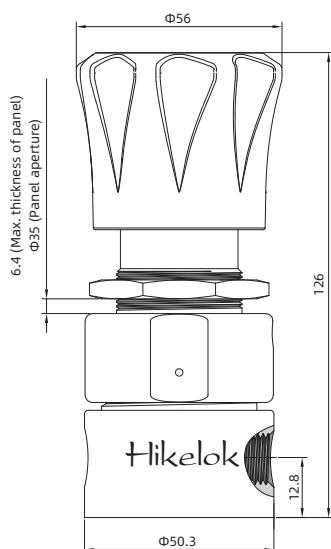

Flow Chart

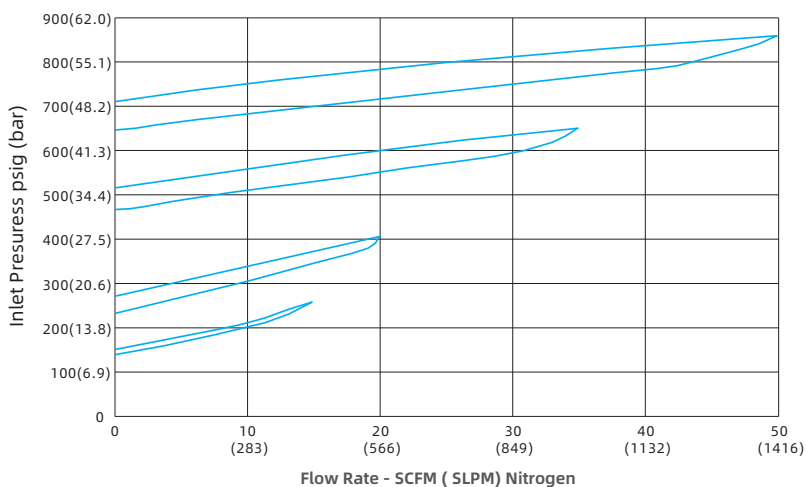

Path Options (LP=Low Pressure; HP=High Pressure)

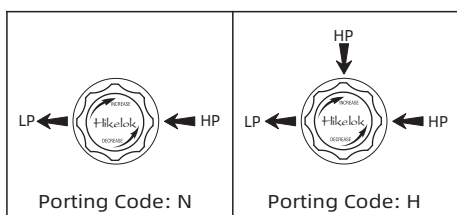

How to Order

BR1 — FNPT4 — IH — 700G — Z — 316L

Series	Inlet Type Outlet Type	Inlet Size Outlet Size	Seat Material	Porting	Controlled Pressure Range	Gauges	O-Ring Material	Body Material
BR1	FNPT Female NPT	4 1/4 in.	PCTFE	N No Gauge Ports	800 100-800 psig	No Gauges	FKM	316 316 S.S.
			P PEEK	H One Gauge Ports	700 100-700 psig	G With Gauges	Z Kalrez	316L 316L S.S.
	I PI		300 40-300 psig	A400 Alloy 400				
					150 40-150 psig	A276 Alloy C276		

High-Pressure Back-Pressure Regulators

BR2 series

Applications

- ❖ Pump discharge pressure control
- ❖ Reactor pressure control
- ❖ Over-pressurization relief

Features

- ❖ Maximum Inlet pressure 10000 psig (689 bar)
- ❖ Economical, compact design
- ❖ Piston sensed design is safe and reliable
- ❖ Optional gauge ports and panel mounting
- ❖ Low handknob torque for easy operation
- ❖ Bubble-tight shutoff at all reseating pressure

Operating Parameters

- ❖ Maximum Inlet Pressure: 10000 psig (689 bar) @ 70°F (21°C)
- ❖ Controlled Pressure Ranges
10-1500 psig (0.69-103 bar), 15-2500 psig (1.03-172 bar), 25-4000 psig (1.72-275 bar),
50-6000 psig (3.45-413 bar), 200-10000 psig (14.79-689 bar)
- ❖ Design Proof Pressure: 150% maximum rated
- ❖ Leakage
Bubble-tight
- ❖ Operating Temperature
PCTFE: -40°F to 165°F (-40°C to 74°C)
PEEK: -40°F to 392°F (-40°C to 200°C)
PI: -40°F to 500°F (-40°C to 260°C)
- ❖ Flow Capacity: Cv=0.10



Standard Materials of Construction

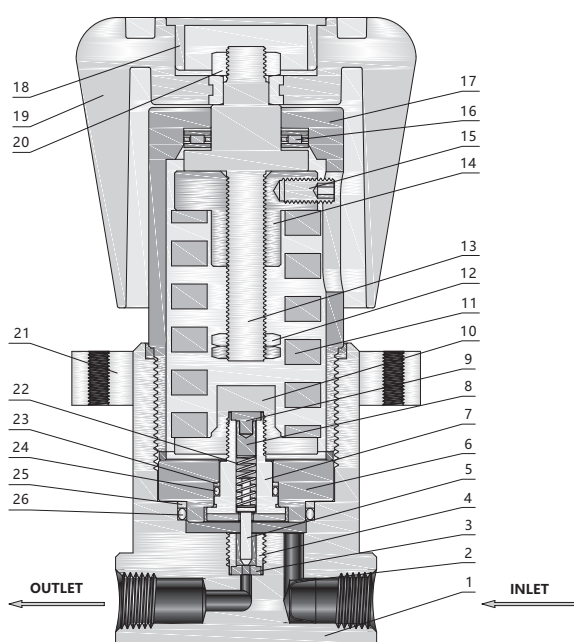

Component	Material Grade
1 Body	316 S.S. / ASTM A479
2 Filter	316 S.S.
3 Seat	PCTFE/PEEK/PI
4 Seat retainer	316 S.S. / ASTM A276
5 Spool	316 S.S. / ASTM A276
6 Piston Base	316 S.S. / ASTM A276
7 Piston	316 S.S. / ASTM A276
8 Spring Seat	316 S.S. / ASTM A276
9 Sealing Seat	PCTFE/PEEK
10 Stop Plate	C36000 / ASTM B16
11 Spring	Galvanized Steel
12 Nut	304 S.S.
13 Stem	316 S.S. / ASTM A276
14 Spring Button	C36000 / ASTM B16
15 Screw	304 S.S.
16 Bearing	Stainless Steel
17 Bonnet	316 S.S. / ASTM A276
18 Handle Cover	Nylon PA66
19 Handle	Nylon PA66
20 Nut	304 S.S.
21 Mounting Seat	6061 / ASTM B211
22 Spring	316 S.S. / ASTM A313
23 O-ring Retaining Ring	PTFE/PEEK
24 O-Ring	FKM/FFKM
25 O-ring Retaining Ring	PTFE/PEEK
26 O-Ring	FKM/FFKM

Dimensions

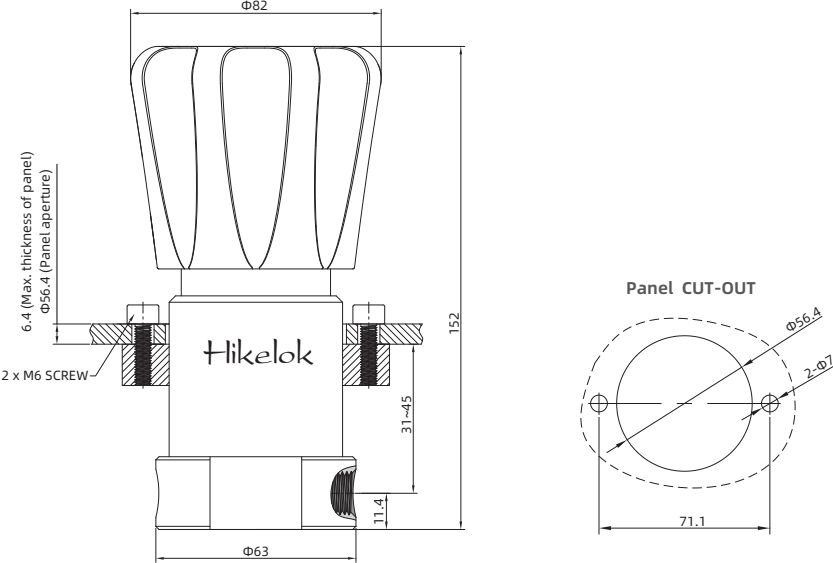

Flow Chart

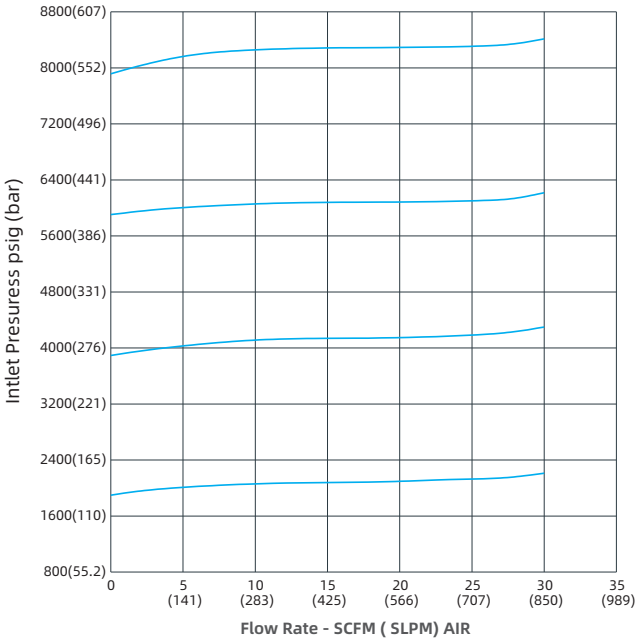
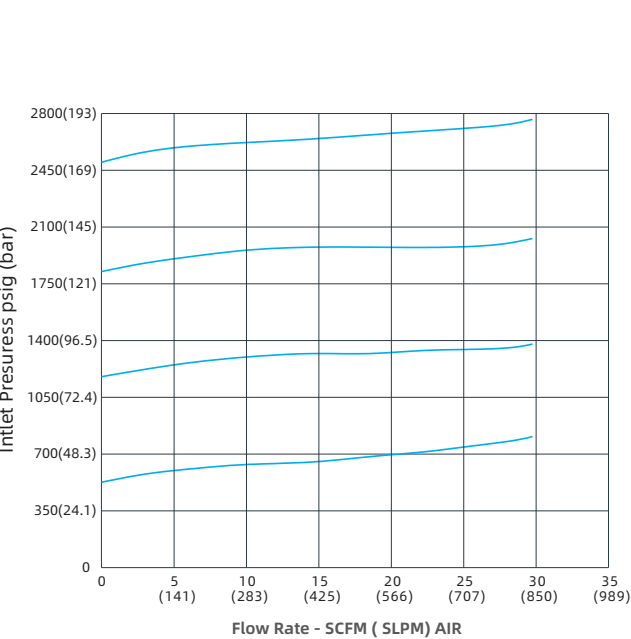

Path Options (LP=Low Pressure; HP=High Pressure)

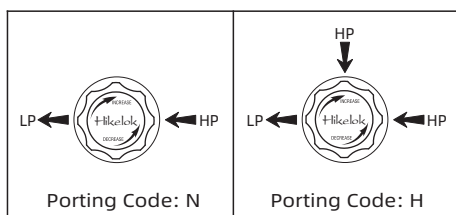

How to Order

BR2 — FNPT4 — IH — 6000 — Z — 316

Series	Inlet Type Outlet Type	Inlet Size Outlet Size	Seat Material	Porting	Controlled Pressure Range	Gauges	O-Ring Material	Body Material
BR2	FNPT Female NPT	4 1/4 in.	PCTFE	N No Gauge Ports	10000 200-10000 psig	No Gauges	FKM	316 316 S.S.
			P PEEK	H One Gauge Ports	6000 50-6000 psig	G With Gauges	Z Kalrez	316L 316L S.S.
	I PI			4000 25-4000 psig	A400 Alloy 400			
				2500 15-2500 psig	A276 Alloy C276			
				1500 10-1500 psig				

Low-Pressure Back-Pressure Regulators

BR3 series

Features

- ❖ Maximum inlet pressure: 250 psig (17.2 bar)
- ❖ Control pressure range:
0-25 psig (0-1.7bar), 0-50 psig (0-3.4bar),
0-100 psig (0-6.9bar), 0-250 psig (0-17.2bar)
- ❖ Operating temperature range: -15°F to 165°F (-26°C to 74°C)
- ❖ Leakage
Internal: Bubble-tight.
External: Design to meet $< 2 \times 10^{-8}$ atm cc/sec He
- ❖ Design proof pressure: 150% x Maximum rated pressure (Based on ASME B31.3)
- ❖ Optional materia 316 stainless steel
- ❖ O-Ring materia FKM, Kalrez
- ❖ Application: Gas and Liquid
- ❖ Low operating torque for easy adjustment
- ❖ Flow capacity: Cv=0.30

Standard Materials of Construction

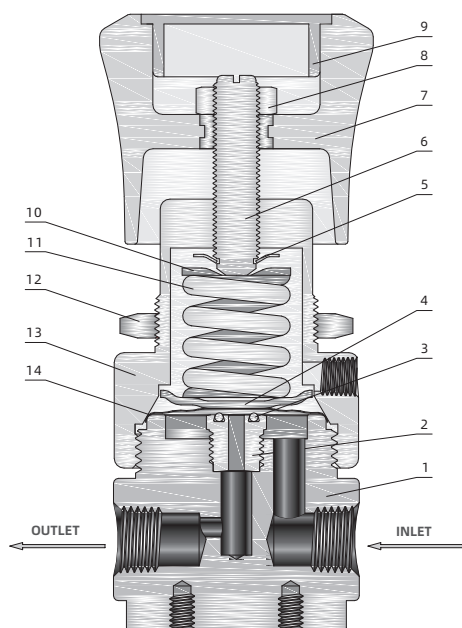

Component	Material Grade
1 Body	316 S.S. / ASTM A479
2 Seat Retainer	316 S.S. / ASTM A276
3 O Ring	FKM
4 Spring Seat	316 S.S. / ASTM A240
5 Bead Flange	Galvanized Steel
6 Stem	C63000 / ASTM B150
7 Handle	Nylon PA66
8 Nut	304 S.S.
9 Handle Cover	Nylon PA66
10 Spring Button	Galvanized Steel
11 Spring	Spring Steel
12 Mounting Nut	S17400 / ASTM B783
13 Bonnet	316 S.S. / ASTM A276
14 Diaphragm	316 S.S.

Dimensions

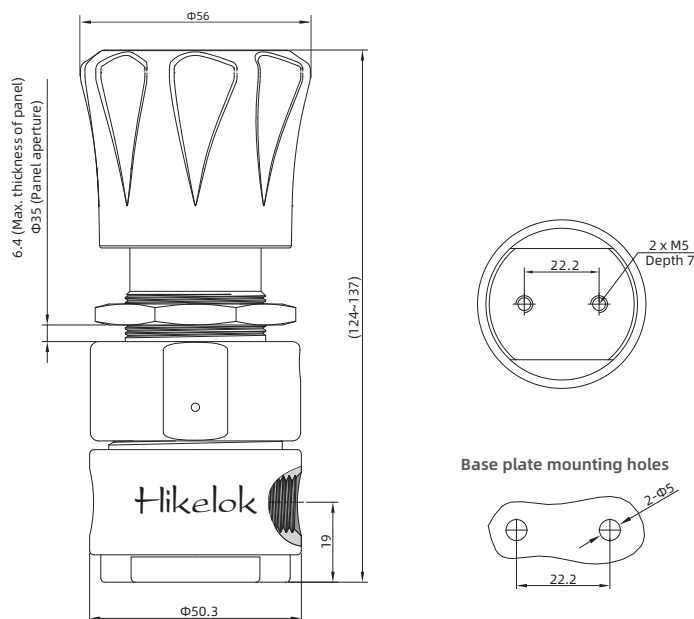

Flow Chart

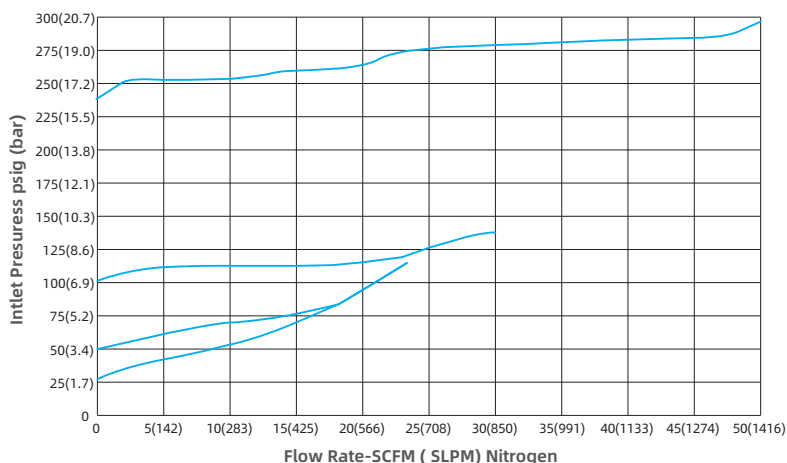

Path Options (LP=Low Pressure; HP=High Pressure)

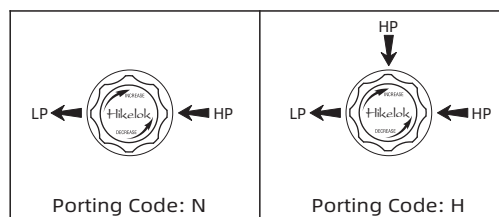

How to Order

BR3 — FNPT4 — H — 25G — Z — 316L

Series	Inlet Type Outlet Type	Inlet Size Outlet Size	Path Options	Controlled Pressure Ranges	Gauges	O-Ring Material	Body Material
BR3	FNPT Female NPT	4 1/4 in.	N No Gauge Ports	250 0-250 psig	No Gauges	FKM	316 316 S.S.
			H One Gauge Ports	100 0-100 psig	G With Gauges	Z Kalrez	316L 316L S.S.
			50 0-50 psig	A400 Alloy 400			
			FBT Female BSPT	25 0-25 psig	A276 Alloy C276		



Ultra-high Purity Regulators

PPR Series

Contents

High Purity Pressure Regulators (PPR1 series)

- ❖ Maximum Inlet Pressure 3500 psig (241 bar)
- ❖ Flow Capacity: Cv = 0.06
- ❖ 1/4" point-of-use

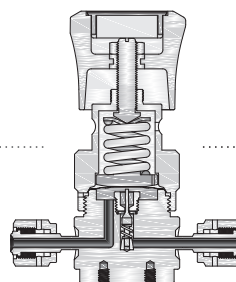

9-41

High Purity High-Flow Pressure Regulators (PPR2 series)

- ❖ Maximum Inlet Pressure 1500 psig (103 bar)
- ❖ Flow Capacity: Cv = 1.2
- ❖ 1/2" point-of-use

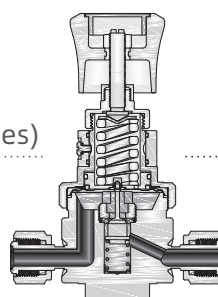

9-44

High Purity Pressure Regulators

PPR1 series

Applications

- ❖ 1/4" point-of-use
- ❖ Gas cabinets
- ❖ Semiconductor manufacturing
- ❖ Valve manifolds boxes
- ❖ Research labs

Features

- ❖ Optimum performance and cleanliness at a great value
- ❖ Internal surface finished to 10 Ra microinch /0.25 micrometer ensures minimal particle generation or entrapment
- ❖ True metal-to-metal body diaphragm seal provides enhanced leak integrity
- ❖ No bias spring or friction device in the flow stream
- ❖ Adjustable stop to limit outlet pressure
- ❖ Positionable ported bonnet ring is available



Operating Parameters

- ❖ Maximum Inlet Pressure: 3500 psig (241 bar)
- ❖ Outlet Pressure Ranges
0-30 psig (0-2.1 bar), 0-60 psig (0-4.1 bar), 0-100 psig (0-6.9bar),
0-150 psig (0-10.3 bar), 0-250 psig (0-17.2 bar)
- ❖ Design Proof Pressure: 150% maximum rated
- ❖ Leakage
Internal: Bubble-tight
External: Design to meet $\leq 2 \times 10^{-9}$ atm cc/sec He
- ❖ Operating Temperature
PCTFE Seat: -40°F to 140°F (-40°C to 60°C)
- ❖ Flow Capacity: Cv = 0.06

Internal Surface Finish

- ❖ 10 Ra microinch / 0.25 micrometer

Cleaning

- ❖ DI water electronic grade cleaned and ES 500 Particle Certified for internal electropolish models

Standard Materials of Construction

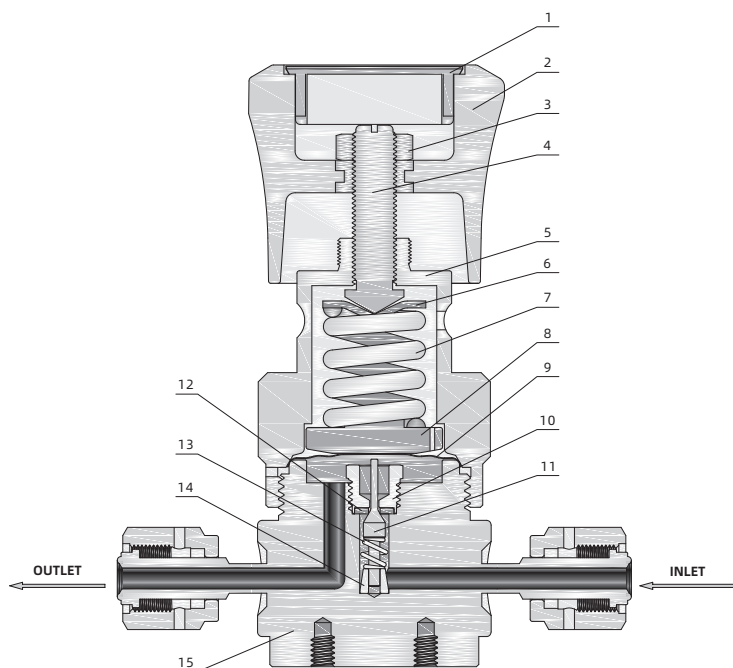

Component		Material Grade / ASTM Specification
		316 S.S.
1	Cover	Nylon PA66
2	Knob handle	Nylon PA66
3	Stem nut	304 S.S.
4	Stem	C36000
5	Bonnet	316 S.S. / A479
6	Spring button	304 S.S.
7	Range spring	Spring Steel
8	stop plate	POM
9	Diaphragm	316 S.S.
10	Seat retainer	316 S.S. / A276
11	Poppet	316 S.S. / A276
12	Seat	PCTFE
13	Poppet spring	Alloy X-750
14	Friction sleeve	316 S.S. / A276
15	Body	316 S.S. / A479

Dimensions

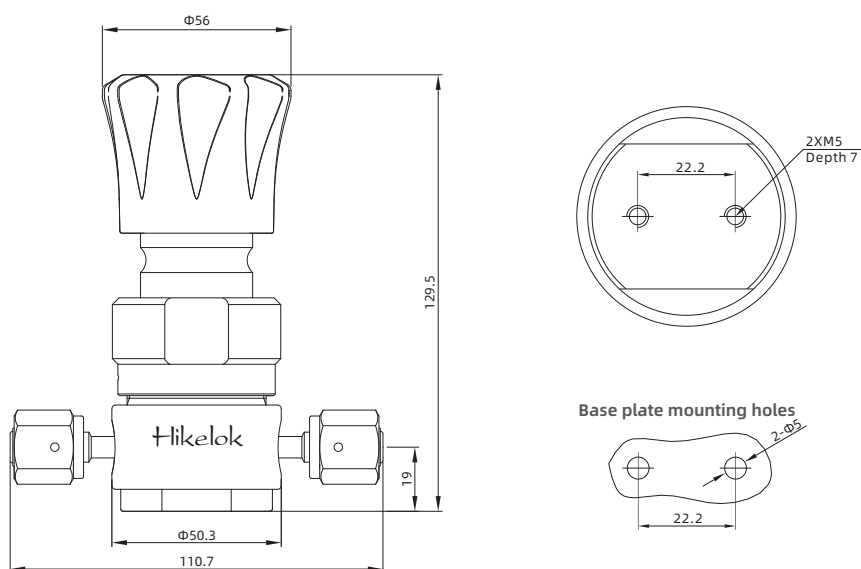

Flow Charts

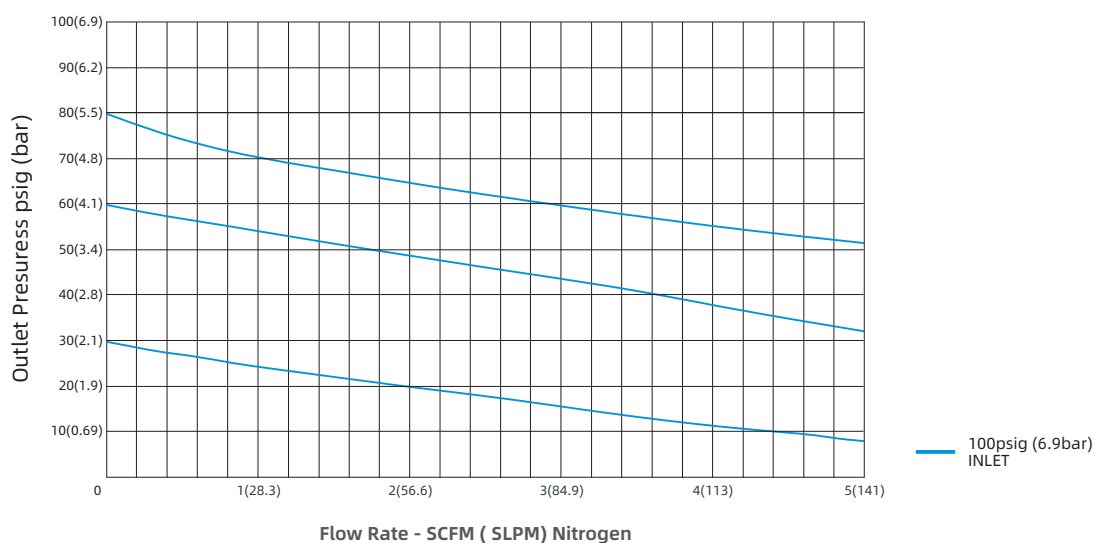

Path Options (LP=Low Pressure; HP=High Pressure)

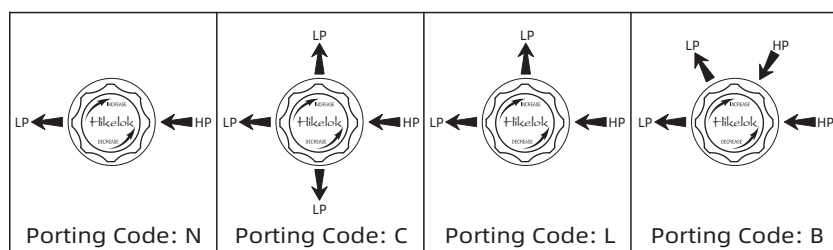

How to Order

Series	Inlet Type Outlet Type	Inlet Size Outlet Size	Seat Material	Porting	Inlet Pressure	Out Pressure	Gauges	Body Material	
PPR1	GFS Male GFS Fitting	2 1/8 in.	PCTFE	N No Gauge Ports	3 3500 psig	250 0-250 psig	No Gauges	316 316 S.S.	
	FGFS Female GFS Fitting	4 1/4 in.		L One Gauge Ports		150 0-150 psig	G With Gauges	316L 316L S.S.	
	FBW Fractional Tube Butt Weld	6 6 mm		C Two Gauge Ports		100 0-100 psig			
	MBW Metric Tube Butt Weld	8 8 mm or 1/2 in.		B Two Gauge Ports		60 0-60 psig			
	RGFS Rotatable Male GFS Fitting						30 0-30 psig		
	IGFS Internal Female GFS Fitting								

High Purity High-Flow Pressure Regulators

PPR2 series

Features

- ❖ 1/2" point-of-use
- ❖ Corrugated non-perforated diaphragm design improves adjustment accuracy and prolongs service life
- ❖ Metal-to-metal seal to ensure minimum external leakage
- ❖ Applicable to corrosive or toxic gases
- ❖ Bottom installation
- ❖ High flow coefficient = Cv 1.2
- ❖ Can be used for gas and liquid.

Technical Data

- ❖ Maximum inlet pressure: 1500psig (103bar)
- ❖ Outlet Pressure Ranges
0-30 psig (0-2.1 bar), 0-60 psig (0-4.1 bar), 0-100 psig (0-6.9 bar),
0-150 psig (0-10.3 bar), 0-200 psig (0-13.8 bar)
- ❖ Leak rates:
Internal: Bubble-tight
External: Design to meet $< 2 \times 10^{-8}$ std cm³/s He
- ❖ Design Proof Pressure: 150% maximum rated
- ❖ Optional material: 316 S.S., 316L S.S., Alloy400, Alloy C276
- ❖ Optional seat: PCTFE(standard), PEEK, PI(optional)
- ❖ Operating Temperature:
PCTFE: -40°F to 176°F (-40°C to 80°C)
PEEK: -40°F to 392°F (-40°C to 200°C)
PI: -40°F to 500°F (-40°C to 260°C)
- ❖ Flow Capacity: Cv = 1.2

Internal Surface Finish

- ❖ 10 Ra microinch / 0.25 micrometer

Cleaning

- ❖ DI water electronic grade cleaned and ES 500 Particle Certified for internal electropolish models



Standard Materials of Construction

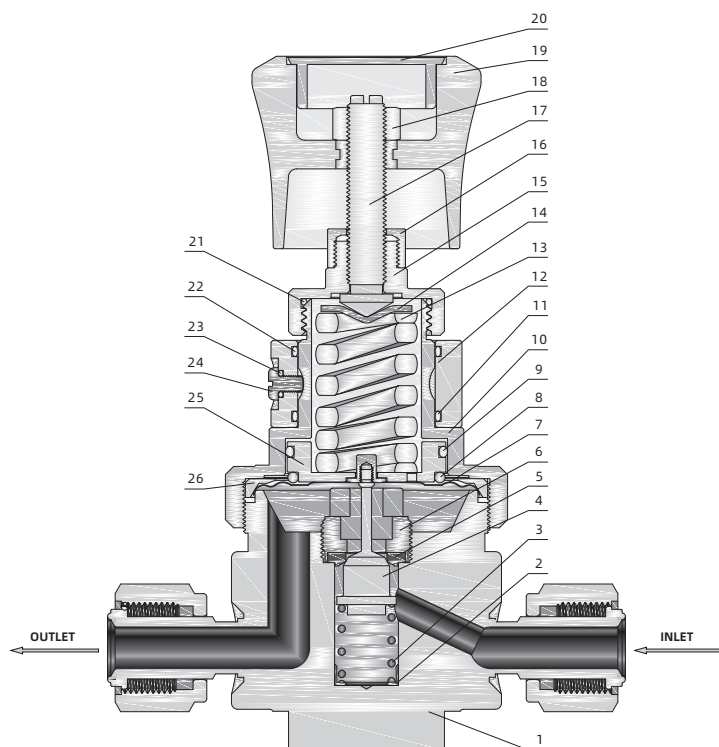

Component	Material Grade	
1	Body	316 S.S. / ASTM A479
2	Spring Base	316 S.S.
3	Spool Spring	Alloy X-750
4	Spool	316 S.S. / ASTM A479
5	Seat	PCTFE / PEEK / PI
6	Seat Retainer	316 S.S.
7	Diaphragm	316 S.S.
8	Support Ring	PTFE/PEEK
9	O-Ring	FKM
10	Bonnet	316 S.S. / ASTM A479
11	O-Ring	FKM
12	Bonnet Rleeve	316 S.S. / ASTM A276
13	Range Spring	Spring Steel
14	Spring Button	304 S.S.
15	Bonnet	316 S.S. / ASTM A479
16	Bonnet Nut	316 S.S.
17	Stem	C36000
18	Stem Nut	316 S.S.
19	Handle	Nylon PA66
20	Cover	Nylon PA66
21	O-Ring	FKM
22	O-Ring	FKM
23	O-Ring	FKM
24	Screws	316 S.S.
25	Spring Support	C36000
26	Bonnet Inner Ring	316 S.S.

Dimensions

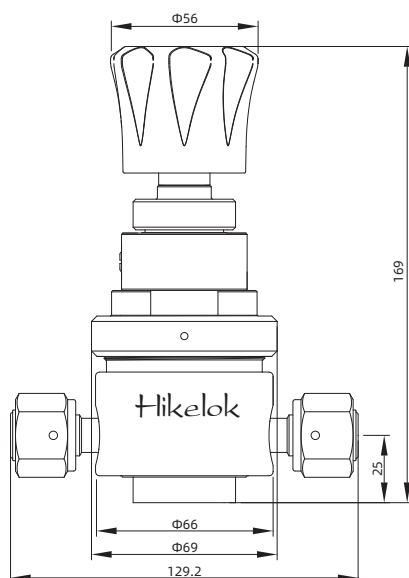

MOUNTING INFORMATION

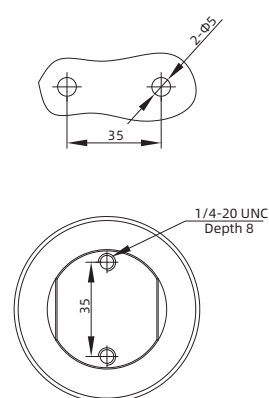

Flow Charts

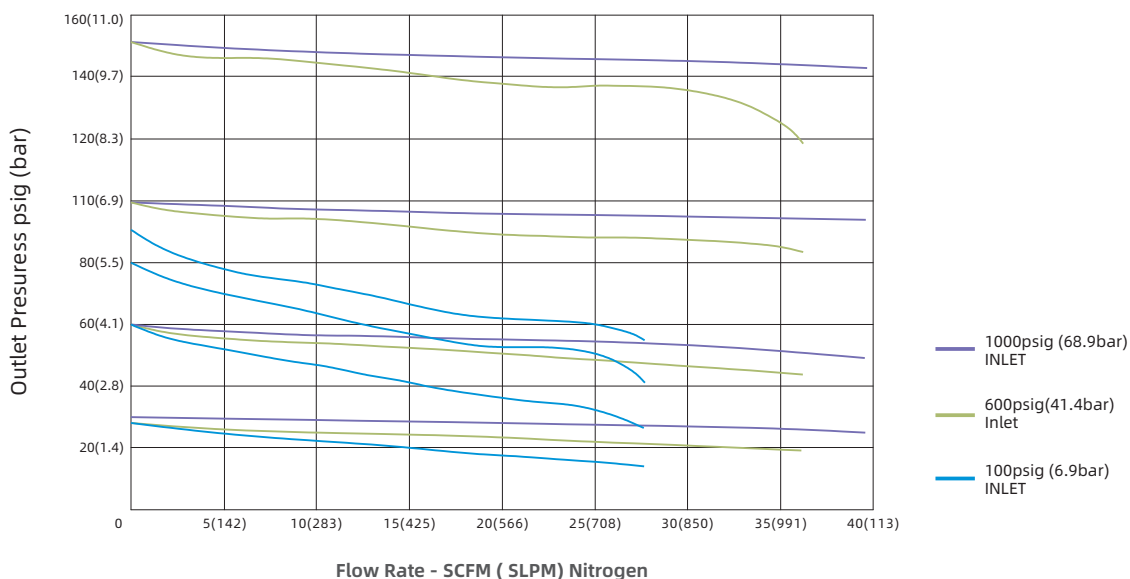

Path Options (LP=Low Pressure; HP=High Pressure)

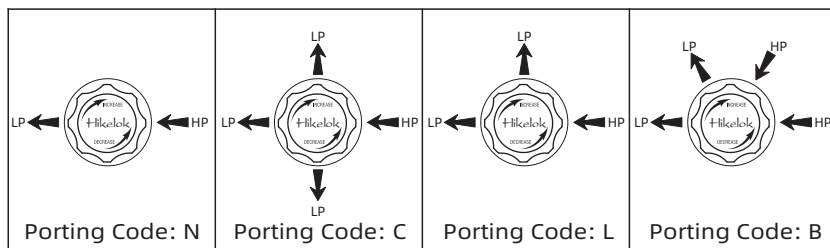

How to Order

PPR2 — FGFS8 — IB — 1200G — 316L

Series	Inlet Type Outlet Type	Inlet Size Outlet Size	Seat Material	Porting	Inlet Pressure	Out Pressure	Gauges	Body Material
PPR2	GF5 Male VCR Fitting	6 3/8 in.	PCTFE	N No Gauge Ports	1 1500 psig	200 0-200 psig	No	316 316 S.S.
	IGFS Internal Female VCR Fitting	8 1/2 in.	P PEEK	L One Gauge Ports		150 0-150 psig	G YES	316L 316L S.S.
	RGFS Rotatable Male VCR Fitting	10 10 mm	I PI	C Two Gauge Ports		100 0-100 psig		
	FGFS Female VCR Fitting	12 12 mm		B Two Gauge Ports		60 0-60 psig		
	FBW Fractional Tube Butt Weld					30 0-30 psig		
	MBW Metric Tube Butt Weld							